



# International Journal for Innovative Engineering and Management Research

A Peer Reviewed Open Access International Journal

www.ijiemr.org

## COPY RIGHT

**2017 IJIEMR.** Personal use of this material is permitted. Permission from IJIEMR must be obtained for all other uses, in any current or future media, including reprinting/republishing this material for advertising or promotional purposes, creating new collective works, for resale or redistribution to servers or lists, or reuse of any copyrighted component of this work in other works. No Reprint should be done to this paper, all copy right is authenticated to Paper Authors

IJIEMR Transactions, online available on 24<sup>th</sup> Oct 2017. Link

[:http://www.ijiemr.org/downloads.php?vol=Volume-6&issue=ISSUE-9](http://www.ijiemr.org/downloads.php?vol=Volume-6&issue=ISSUE-9)

Title: **DETECTING AND PREVENTION OF VEHICLE ACCIDENT USING ARM11 & LINUX**

Volume 06, Issue 09, Pages: 225 – 230.

Paper Authors

**Y. PHANENDRA, Y.VENKATESWARA REDDY**

Malla Reddy Institute Of Technology Maisammaguda, Bhadurpalle, Hyderabad, Telangana, India.



USE THIS BARCODE TO ACCESS YOUR ONLINE PAPER

To Secure Your Paper As Per **UGC Guidelines** We Are Providing A Electronic Bar Code

## DETECTING AND PREVENTION OF VEHICLE ACCIDENT USING ARM11 & LINUX

<sup>1</sup>Y. PHANENDRA, <sup>2</sup>Y.VENKATESWARA REDDY

<sup>1</sup>M.Tech Scholar, Department of E.C.E(VLSI & E.S), Malla Reddy Institute Of Technology Maisammaguda, Bhadurpalle, Hyderabad, Telangana, India

<sup>2</sup>Associate Professor, Department of E.C.E, Malla Reddy Institute of Technology, Bhadurpalle, Hyderabad, Telangana, India

**ABSTRACT:** Security in travel is primary concern for everyone. This Project describes a design of effective alarm system that can monitor an automotive / vehicle / car condition in traveling. This project is designed to inform about an accident that is occurred to a vehicle to the family members of the traveling persons. This project uses a vibration sensor which can detect the abrupt vibration when an accident is occurred. This sends a signal to microcontroller. This Project presents an automatic vehicle accident detection system using GPS modem. The system can be interconnected with the car alarm system and alert the owner on his mobile phone. This detection and messaging system is composed of a GPS receiver and Microcontroller. GPS Receiver gets the location information from satellites in the form of latitude and longitude. The Microcontroller processes this information and this processed information is sent to the user/owner using IoT. An IoT module is interfaced to the MCU. This updates information in the web server to inform about this accident. This enables to monitor the accident situations and it can immediately alert the police/ambulance service with the location of accident. The project is built around the ARM11 micro controller. This processor provides all the functionality of the alert system. GPS gives only the longitude and latitude values but by using Android application in the mobile we can easily get the location name from where the message has been sent.

**KEYWORDS:** ARM11, vibration Sensor, RFID, IOT Environment, GPS, LINUX OS

### 1. INTRODUCTION

The advent of the mobile phone and Internet of Things (IoT) industries reshaped the way people communicate and brought a paradigm shift to public and private services [1]. This ever evolving technology marked the beginning of new era affecting the lives of people and various businesses. This paper conveys a smart and reliable IoT system solution which instantly notifies the

PSO headquarter whenever an accident takes place and pinpoints its geographic coordinates on the map. When an accident takes place, a shock sensor detects it. Then, an algorithm is applied to process the sensor signal and send the geographic location along with some ancillary information to the PSO headquarter, indicating accident occurrence. This is a

promising system expected to aid in the tedious rescuing process by reporting in a matter of seconds the location of an accident, the passengers injured, blood types, thus lowering death's rates. The geographical data collected from this system could be relied upon as admissible evidence or indicator of the road state and conditions.

## II.SYSTEM OVERVIEW

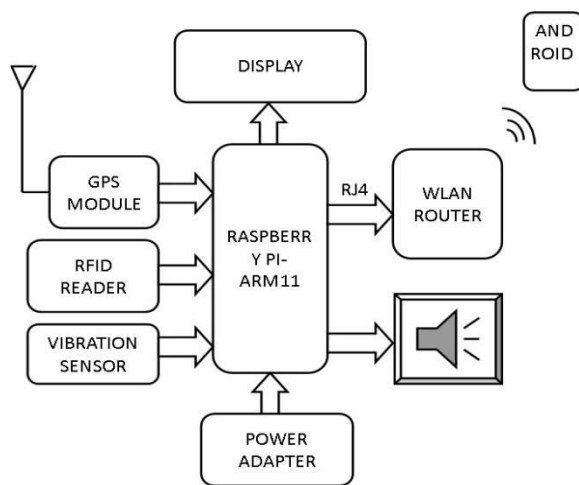

Fig.1 System Architecture

## III.METHODOLOGY OF DETECTION

The current existing solutions that provide assistance to passengers in case of vehicle accident occurrence are mainly concerned with user interaction after the incident happened. Those mobile solutions require that the injured must launch the app and request help manually and that would not be possible if he/she is under critical or serious non-vital situation. The situation becomes even worse if passengers went under unconscious state. Our proposed solution is a smart IoT system consisting of architecture, design, and implementation. This system requires no user interaction

during or after the accident; consequently, it provides instant automated vehicle accident detection and reporting. This method is applicable for any vehicle used in transportation and mainly for cars accidents. The primary users of this solution are the public safety organizations rescue teams (like Red Cross, Emergency Management Agencies, Law Enforcement Agencies, Fire Departments, Rescue Squads, and Emergency Medical Services, etc...). The main contributions of this project are: (a) Developing a new smart IoT solution which helps the community in reducing the death rate resulting from vehicle accidents. (b) Ensuring that no passenger (injured) intervention is required during or after the accident. (c) Transmitting automatically the basic medical information needed by the rescue teams to the PSO headquarter. (d) Collecting geographical data which can be fed to a data mining engine to extract roads conditions, and to generate descriptive statistics reports about vehicle accidents. (e) Implementing a navigation system to find the closest rescue team to the crash.

## RASPBERRY PI

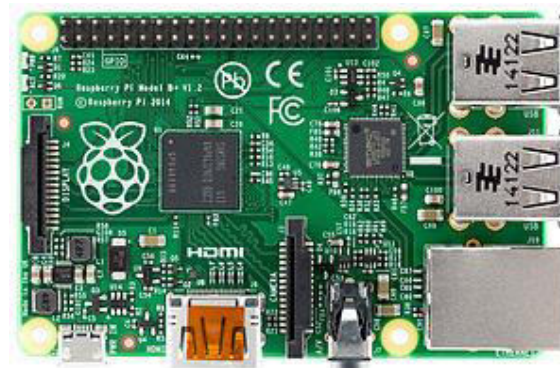

Figure 2: Raspberry Pi Board

Raspberry Pi (shown in Fig. 2) is a credit-card-sized single board computer developed in the UK by Raspberry Pi foundation with the intention of stimulating the teaching of basic computer science in schools. It has two models; Model A has 25 6Mb RAM, one USB port and no network connection. Model B has 5 12Mb RAM, 2 USB ports and an Ethernet port. It has a Broadcom BCM2835 system on a chip which includes an ARM1176JZF -S 700 MHz processor, Video Core IV GPU, and an SD card. The GPU is capable of Blu-ray quality playback, using H.264 at 40MBits/s. It has a fast 3D core accessed using the supplied OpenGL ES2.0 and Open VG libraries. The chip specifically provides HDMI and there is no VGA support. The foundation provides Debian and Arch Linux ARM distributions and also Python as the main programming language, with the support for BBC BASIC, C and Perl, detailed description of Raspberry Pi board has been given in Fig. 2 (Raspberry Pi user guide).

### **INTERNET GATEWAY:**

The ARM11 is connected to a router with a wired serial connection. The router runs open source embedded Linux software, providing networking functionality to connect the internet. This essentially provides internet access to the ARM11 board. Router acts as an IoT application gateway and interconnects. A private IPv6 network using a Virtual Private Network (VPN) is used for connecting the IoT application gateway to the server.



**Figure 3: Internet Router**

The server collects sensor data forwarded by the application gateway and store in a database for further processing and then to be viewed via a website. Data can be viewed in terms of previous day, week, and month time periods graphically. In the present setup, heterogeneous sensing units are designed and developed indigenously for intelligent home monitoring systems to integrate with IoT networks.

### **VIBRATION SENSOR**

The Vibration module based on the vibration sensor SW-420 and Comparator LM393 to detect if there is any vibration that beyond the threshold. The threshold can be adjusted by the on-board potentiometer. When this no vibration, this module output logic LOW the signal indicate LED light and vice versa. Uses For a variety of shocks triggering, theft alarm, smart car, an earthquake alarm, motorcycle alarm. This module when compared with normally open pneumatic shock sensor module, shock triggered much longer can drive relay module Module features: the use of the company's production of SW-420 normally closed type vibration sensors. compactor output signal clean wave well, driving ability, 15mA rated voltage and 3.3V-5V output: digital

switching output (0 and 1) a bolt-hole for easy installation small Board PCB dimensions: 3.2cm x 1.4cm using wide LM393 voltage compactor Module description: the product when it is not shock, vibrate switch is closed on-State, output output low level, the green indicator light is on; When vibration, vibration switches disconnected moments, output output line, the Green led is not lit; the output can be directly connected to the micro controller, by single-chip computer to detect high or low level, to detect whether there is vibration, alarm function

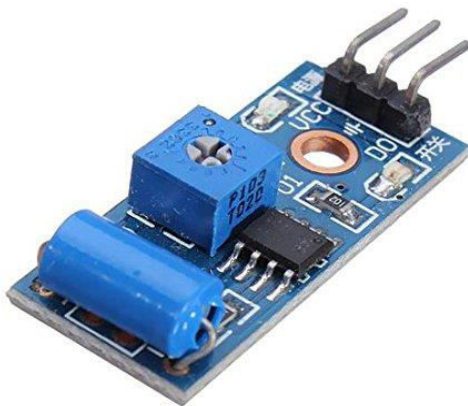
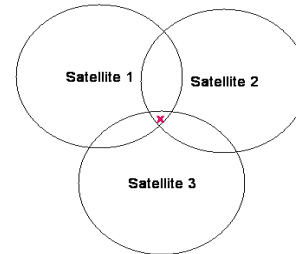

Fig 4. Vibration sensor

## GPS TECHNOLOGY

The Global Positioning System (GPS) is a satellite based navigation system that sends and receives radio signals. A GPS receiver acquires these signals and provides the user with information. Using GPS technology, one can determine location, velocity and time, 24 hours a day, in any weather conditions anywhere in the world for free.

A 2-D Calculation Illustration



x Marks the spot because the user must be somewhere on the satellite 1 circle, satellite 2 circle and satellite 3 circle, plus or minus 100meters

Fig 5. GPS Technology

GPS was formally known as the NAVSTAR (Navigation Satellite Timing and Ranging). Global Positioning System was originally developed for military. Because of its popular navigation capabilities and because GPS technology can be accessed using small, inexpensive equipment, the government made the system available for civilian use. The USA owns GPS technology and the Department of Defense maintains it.

## RFID TECHNOLOGY

RFID is short for Radio Frequency Identification. Generally a RFID system consists of 2 parts. A Reader, and one or more Transponders, also known as Tags. RFID systems evolved from barcode labels as a means to automatically identify and track products and people. In every RFID system the transponder Tags contain information. This information can be as little as a single binary bit, or be a large array of bits representing such things as an identity code, personal medical information, or literally any type of information that can be stored in digital binary format. Shown is a RFID transceiver that communicates with

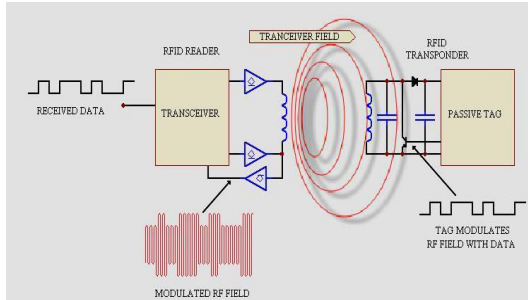

a passive Tag. Passive tags have no power source of their own and instead derive power from the incident electromagnetic field. Commonly the heart of each tag is a microchip. When the Tag enters the generated RF field it is able to draw enough power from the field to access its internal memory and transmit its stored information. When the transponder Tag draws power in this way the resultant interaction of the RF fields causes the voltage at the transceiver antenna to drop in value. This effect is utilized by the Tag to communicate its information to the reader. The Tag is able to control the amount of power drawn from the field and by doing so it can modulate the voltage sensed at the Transceiver according to the bit pattern it wishes to transmit.

#### IV. ROBUST SYSTEM DESIGN

#### V. RESULTS

The scenarios of fall or accident of a vehicle are mainly divided into two groups including fall by themselves and crash by other objects. Thus, the device may be tested with a limited number of situations of accidents. The car accident detection using vibration sensor has been implemented and tested. Typical data for motorcycle fall without external force or linear fall is shown in Fig 7. For linear fall, only acceleration on

z-coordinate is used to determine the accident.

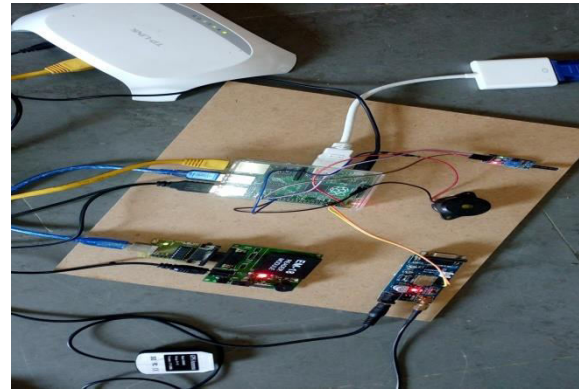
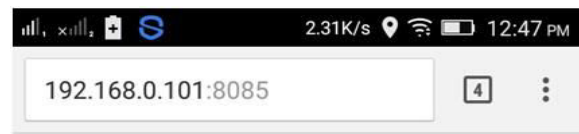

Fig 7. Hardware setup in the vehicle



### Vehicle accident detection

**Accident Detected**  
**LO:07808.4962**  
**LA:1718.7134**  
**Name: Phani Mobile Number: 9493376963**  
**Blood Group: AB+**  
**Name: Brmi Mobile Number: 9703386259**  
**Blood Group: O+**  
**Name: Kiran Mobile Number: 7744717458**  
**Blood Group: B+**  
**Name: Anil Mobile Number: 8893372263**  
**Blood Group: A+**

Fig.8 passengers details when accident occurred

### CONCLUSIONS AND FUTURE SCOPE

we proposed and implemented an IoT system which may help the community decreasing the death rates resulting from vehicles accidents. Results showed that this solution provided many advantages compared to traditional systems, namely,

minimizing injured passengers interaction, providing basic medical information to rescue teams, recognizing exact and accurate accidents locations, and facilitating the routing process. Reliability test showed that the system is robust, that is, available and serviceable specially when the IoT device keeps sending continuous notification of crash occurrence until it makes sure its reception by the headquarter as shown in Fig. 1. Also the data collected from this system can be fed to data mining engine and hence, can serve the PSO in generating statistical reports related to the number of accidents, number of injured, bank of blood donors, and road conditions. Our future vision is to enhance the system and push forward toward integrating it into each vehicle during the manufacturing phase. Also, this system could be managed to get passenger information using a primary key like the Social Security Number (SSN) from a governmental centralized database.

## REFERENCES:

- [1]. Honda motor co., ltd. "Motorcycle airbags system (Press information September 2005)," unpublished.
- [2]. Elite security supplies "The 3-stage AcuTrac Motorcycle Tracking System," <http://www.gpsfast.com>.
- [3]. M. Lu, W. chen, X. Shen, H.C. Lam and J. Liu, "Positioning and tracking construction vehicle in highly dense urban areas and building Construction sites," Automation in Construction, vol. 16, issue 5. pp.647-656, August 2007.

- [4] N. Jinaporn, S. Wisadsud, P. Nakonrat, A. Suriya, "Security system against asset theft by using radio frequency identification Technology," IEEE Trans. ECTI-CON 2008.

## GUIDE PROFILE:



Y.Venkateswara Reddy, M.Tech, (Ph.D) Associate Professor, Department of E.C.E, Malla Reddy Institute of Technology, [yvr459@gmail.com](mailto:yvr459@gmail.com), 7893377799

I, Y.Venkateswara Reddy, working as Associate Professor in the Department of E.C.E, Malla Reddy Institute of Technology. I have 10 Years of Teaching Experience and have guided many PG Students for their M.tech projects.

## STUDENT PROFILE

**Name:** Y. phanendra



M.Tech (VLSI & EMBEDDED SYSTEM)  
[phanendra.yarra@gmail.com](mailto:phanendra.yarra@gmail.com) MALLA  
REDDY INSTITUTE OF TECHNOLOGY  
**Address:** Maisammaguda, Bhadurpalle,  
Hyderabad, Telangana, India