



## COPY RIGHT

**2017 IJIEMR.** Personal use of this material is permitted. Permission from IJIEMR must be obtained for all other uses, in any current or future media, including reprinting/republishing this material for advertising or promotional purposes, creating new collective works, for resale or redistribution to servers or lists, or reuse of any copyrighted component of this work in other works. No Reprint should be done to this paper, all copy right is authenticated to Paper Authors

IJIEMR Transactions, online available on 21<sup>st</sup> July 2017. Link :

<http://www.ijiemr.org/downloads.php?vol=Volume-6&issue=ISSUE-5>

Title: Finite Element Analysis of Pressure Vessel.

Volume 06, Issue 05, Page No: 1973 – 1980.

Paper Authors

**\* K.SUSHMA, MR.DR.J.S.SONI.**

\* Dept of Mechanical Engineering, Bharath institute of Engineering and Technology.



USE THIS BARCODE TO ACCESS YOUR ONLINE PAPER

To Secure Your Paper As Per **UGC Guidelines** We Are Providing A Electronic Bar Code



## FINITE ELEMENT ANALYSIS OF PRESSURE VESSEL

\*K.SUSHMA,\*\*MR.DR.J.S.SONI

\*PG Scholar, Dept of Mechanical Engineering, Bharath institute of Engineering and Technology, T.S, India

\*\*Head Of The Department, Dept of Mechanical Engineering, Bharath institute of Engineering and Technology, T.S, India

### ABSTRACT

Cylindrical pressure vessels are widely used for commercial, under water vehicles and in aerospace applications. At present the outer shells of the pressure vessels are made up of conventional metals like steels and aluminium alloys. The payload performance/ speed/ operating range depends upon the weight. The lower the weight the better the performance, one way of reducing the weight is by reducing the weight of the shell structure. The use of composite materials improves the performance of the vessel and offers a significant amount of material savings. Moreover, the stacking sequence is very crucial to the strength of the composite material. This Project involves various objective functions such as stiffness, buckling load and Weight at each level of optimization. Usually composite pressure vessels are designed for minimum mass under strength constraints. A graphical analysis is presented to find optimum fiber orientation for given layer thicknesses. In the present work, an analytical model is developed for the Prediction of the minimum buckling load with / without stiffener composite shell of continuous angle ply laminas ( $\pm 45^\circ, \pm 55^\circ, \pm 65^\circ, \pm 75^\circ, \pm 85^\circ$ ) for investigation. Comparisons are made for two different approaches i.e. the finite element model and the theoretical model. A 3-D finite element analysis is built using ANSYS-15.0 version software into consideration, for static and buckling analysis on the pressure vessel.

**Key words:** Composite material, Shells, Fiber orientation, Layer thickness, Stiffeners, Critical Pressure and Buckling.

### INTRODUCTION:

Pressure vessels are important because many liquids and gases must be stored under high pressure. Special emphasis is placed upon the strength of the vessel to prevent explosions as a result of rupture. Codes for the safety of such vessels have been developed that specify the design of the container for specified conditions. Most pressure vessels are required to carry only low pressures and thus are constructed of tubes and sheets rolled to form cylinders. Some pressure vessels must carry high pressures, however, and the thickness of the vessel walls must increase in order to provide adequate strength. Interest in studying of the shell arises

from the fifties of twentieth century. The assemblies, containing thin shells, find wide use in the modern engineering, especially in ships, aircraft and spacecraft industry. The shell vibrations and buckling modes are analyzed by means of numerical methods, to clarify qualitatively the critical loads and different buckling modes.

In today's aerospace and aircraft industries, structural efficiency is the main concern. Due to their high specific strength and light weight, fibre reinforced composites find a wide range of applications. Light weight compression load carrying structures form part

of all aircraft, and space vehicle fuel tanks, air cylinders are some of the many applications.

In the present work, design analysis of fiber reinforced multi layered composite shell, with optimum fiber orientations; minimum mass under strength constraints for a cylinder with or without stiffeners under axial loading for static and buckling analysis on the pressure vessel has been studied. Cylindrical shells (see Fig.1.1) such as thin-walled laminated composite unstiffened vessels like deep submarine exploration housings and autonomous underwater vehicles are subjected to any combination of in plane, Out of plane and shear loads due to the high external hydrostatic pressure during their application. Due to the geometry of these structures, buckling is one of the most important failure criteria. Buckling failure mode of a stiffened cylindrical shell can further be subdivided into global buckling, local skin buckling and stiffener crippling. Global buckling is collapse of the whole structure, i.e. collapse of the stiffeners and the shell as one unit. Local skin buckling and the stiffeners crippling on the other hand are localized failure modes involving local failure of only the skin in the first case and the stiffeners in the second case.



**Fig 1.1.Cylindrical Pressure Vessel**

In the present work, an analytical model is developed for prediction of optimum fiber orientations for given layer thicknesses, and mainly minimum buckling load for with or without stiffener composite shell under multilayered continuous angle-ply loading condition is investigated. The model developed is more general in the sense that any configuration of stiffeners, on either one side or both sides of the shell can be modeled accurately. Stiffened shells having either symmetrical or unsymmetrical shell laminates can also be modeled with equal ease using this model. Grid stiffened cylindrical shells are the shells having a certain kind of stiffening structures either on inner, outer or both sides of the shell and significantly increases the load resistance without much increase in weight. To further reduce the weight, both the shell and the stiffeners are made using fiber reinforced polymers. The promising future of stiffened composite cylinder has in turn led to an extensive research work in this area. For the sake of analysis, shell elements (shell 91 & solid 46) were used and analysis was carried out with the aid of the commercial package, ANSYS-15.0. Due to the expensive nature of composite cylinder test specimens, experimentation could not be performed.

## **1.1 INTRODUCTION TO THIN COMPOSITE SHELLS**

The shell whose wall thickness is small compared to the radius of curvature and the corresponding radius of twist is known as thin shell. Plate and shell structures are used in a lightweight load bearing structural parts for various modern aerospace, offshore, nuclear, automotive, and civil engineering structures. These shells are subjected to compressive loads. In the case of air crafts, they are subjected to fluctuating flight loads, which also produce compressive components. These compressive loads cause buckling of the shell



structure. The analysis of composite shell structures requires consideration of a variety of failure modes. Often analysis programs cannot predict all failure modes using a single analysis model, and consequently structural designers must use a variety of analysis tools. It is also common that for a given failure mode, it is difficult to obtain the same result using different programs. There is no need to argue that composite shells are important in modern technology.

## 1.2 COMPOSITE MATERIALS

Composites are considered to be combinations of materials differing in composition or form on a macro scale. The constituents retain their identities in the composite i.e. they do not dissolve or otherwise merge completely into each other although they act in the idea of a composite material is not a new or recent one concert. In nature, one can find out many composite materials, for example wood is a fibrous natural composite (cellulose fibrous in lignin matrix). Bone is yet another example of natural composites. Our ancestors invented composite by mixing straw and clay to make bricks. Straw is fiber reinforcement and clay is the matrix. The first glass fiber reinforced polymer was developed in 1940. The origin of distinct discipline of composite materials started in 1960's. Extensive research has been done on composite material since 1965. One difference between laminated composites and traditional engineering materials is that a composite's response to loads is direction dependent. Monolithic metals and their alloys can't always meet the demands of today's advanced technologies. The composite materials exhibit high specific strength and high specific modulus resulting in substantial reduction of weight of the components, thus improves efficiency, and results in energy savings. One of the main advantages of composite materials is the flexibility involved in getting the desired strength and stiffness in

the direction required. Carbon fibers are very common in high-modulus and high-strength applications. It is well known that the measured strength of most materials is much smaller than their theoretical strength because of presence of imperfections or inherent flaws in the materials. Flaws in the form of cracks that lies perpendicular to the direction of load are particularly detrimental to the strength. It is found that non polymeric materials have higher strength along their lengths because of small cross sectional fibers, the flaws are minimized.

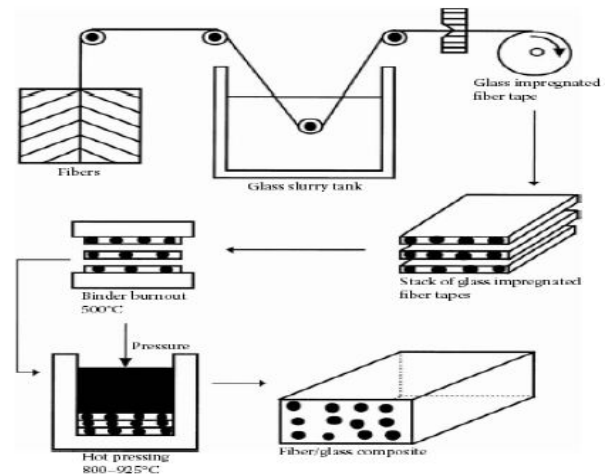

**Fig. 1.2. Schematic Matrix Composite Laminates Manufacturing**

One of the most common methods to manufacture matrix composites is called the hot pressing method. Glass fibers in continuous tow are passed through slurry consisting of powdered matrix material, Solvent such as alcohol, and an organic binder as shown in fig 1.2.

## LITERATURE SURVEY:

Composites are the materials, which are tailored by combining two or more materials to get properties that are not attainable in any of its constituents alone. These materials contain dispersed fibers, particles or whiskers embedded in a matrix, which may be metallic,

polymer or ceramic material. Composites are made from constituents, which can be grouped as (a) matrix (continuous phase) and (b) reinforcements (either continuous or discontinuous) in the form of particles, flakes, whiskers and short fibers (Alman, 2001). These combinations of materials can result in a newly synthesized material having unique and tailored properties such as low density, exceptional strength and stiffness, fatigue and corrosion resistance, high thermal conductivity and low coefficient of thermal expansion (Srivatsan *et al*, 1995).

Due to their light weight, composites are being extensively used in manufacturing components of ground, space and aerospace vehicles. Composite technology provides us with the ability to create new multifunctional materials that can offer all the desirable characteristics required for a given application combined with low cost and near net-shape manufacturing processes, thereby expanding the vision for new materials and applications. On the basis of nature of matrix materials, the composites may be classified as metal matrix composites (MMCs), ceramic metal composites (CMCs) and polymer matrix composites (PMCs) (Aggarwal and Broatman, 1980).

Amongst the above mentioned composites, MMCs are the most important in present day material technology, as their development is pivotal to the growth of a number of leading technologies such as space, aerospace and shipbuilding technology. Metal matrix composites are based on metals or their alloys reinforced with fibers, particles or whiskers. A metal matrix composite combines into a single material a metallic base with a reinforcing constituent, which is usually non-metallic and is commonly a ceramic. Metal matrix composites containing particles are generally isotropic and are relatively cheap. Due to their superior stiffness, high strength at elevated temperatures and better creep characteristics, many of these composites are finding

increasing application in components operating under elevated temperatures. In comparison to PMCs, MMCs can sustain higher service temperature, possess greater thermal and electrical conductivities and greater strength in shear and compression (Park *et al*, 1990). The increasing demand of ceramic like properties in metallic materials is mainly motivated by the need of weight reduction of dynamic systems operating under elevated temperatures, where PMCs are not capable enough. If the lighter composites can replace components in motion, there exists a great possibility for further weight reduction of the surrounding components in an engineering system due to reduction of moving masses. Therefore, the MMCs are an attractive choice for variety of applications such as components of combustion engine, brake systems, stiff beams, load transfer elements in vehicles (support, personal and utility cars, rail transport), aerospace applications (turbine engines, helicopters, spacecrafts, airplanes, missile guidance systems), thermal management components in high power electronics, thermally cycled components (heat sinks, electronic packaging, mechanically loaded heat transfer elements) and machine components with high wear resistance but with low weight (textile machines, packaging machines, transmission system). Rapid growth in technology has ushered in an era when it is possible to synthesize materials for components that exhibit graded-variation in properties. Typically, under severe environments such as high temperature or high thermal gradients, where conventional materials (metals or ceramics) may not survive alone. Thus, the concept of Functionally Graded Materials (FGMs) emerged and led to the development of superior heat resistant materials. FGMs are composites that are provided with heat-resistant ceramics on the high-temperature side and tough metals with high thermal conductivity on

the low temperature side. In FGMs, the constituents or their contents vary with respect to position coordinates, which enable them to provide unique performance (Gupta *et al*, 2005).

## METHODOLOGY

### STEPS IN A MODEL ANALYSIS

The procedure for a model analysis consists of four main steps:

1. Build the model.
2. Apply loads and obtain the solution.
3. Expand the modes.
4. Review the results

### 3.9 REVIEW THE RESULTS:

Results from a model analysis (that is, the model expansion pass) are written to the structural results file, *Jobname.RST*. Results consist of:

- Natural frequencies
- Expanded mode shapes
- Relative stress and force distributions

#### 3.9.1 PROBLEM DESCRIPTION:

This is a modal analysis of a wing of a model plane. The wing is of uniform configuration along its length, and its cross-sectional area is defined to be a straight line and a spline, as shown. It is held fixed to the body on one end and hangs freely at the other. The objective of the problem is to demonstrate the wing's modal degrees of freedom Weight calculations have been carried out by varying the materials like conventional and composite materials, to find out the material that has minimum weight. Carbon fiber Composites are roughly quarter weight of the st Length (height „h“) of the

cylinder  $L = 1030$  mm Diameter of the cylinder  $d = 670$  mm

Thickness of the shell  $t = 10$  mm

$$R - r = t \quad r = R - t$$

$$r = 335 - 10$$

$$r = 325 \text{ mm}$$

$$\text{Volume} = \pi r^2 h = \pi \times (335^2 - 325^2) \times 1030 = 21356546.86 \text{ mm}^3 = 21.356546 \times 10^6 \text{ mm}^3 = 21.356546 \times 10^{-3}$$

$$\text{Density } \rho = \text{mass} / \text{Volume} \quad \text{Weight} = m \cdot g = \rho \cdot v \cdot g \quad \text{Density of steel}$$

$$= 7.86 \text{ gm} / \text{cm}^3 = 7.86 \times 10^3 \text{ m}$$

$$= \rho V = 7.86 \times 21.356 \times 10^{-3} = 167.858 \text{ kg}$$

$$\text{Glass Epoxy } 2.1 \times 10^3 \times 21.356 \times 10^{-3} = 44.847 \text{ kg}$$

#### Carbon Epoxy

$$1.55 \times 10^3 \times 21.356 \times 10^{-3} = 33.10 \text{ kg}$$

#### Introduction to Catia V5 R20:

CATIA-V5 is the industry's de facto standard 3D mechanical design suit. It is the world's leading CAD/CAM /CAE software, gives a broad range of integrated solutions to cover all aspects of product design and manufacturing. Much of its success can be attributed to its technology which spurs its customer's to more quickly and consistently innovate a new robust, parametric, feature based model. Because that CATIA-V5 is unmatched in this field, in all processes, in all countries, in all kind of companies along the supply chains. Catia-v5 is also the perfect solution for the manufacturing enterprise, with associative applications, robust responsiveness and web connectivity that make it the ideal flexible engineering solution to accelerate innovations. Catia-v5 provides easy



to use solution tailored to the needs of small medium sized enterprises as well as large industrial corporations in all industries, consumer goods, fabrications and assembly. Electrical and electronics goods, automotive, aerospace, shipbuilding and plant design. It is user friendly solid and surface modeling can be done easily.

The model is as shown in the figure 2 as shown below:

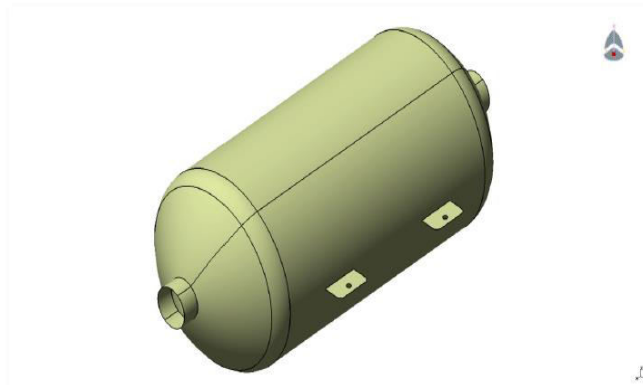

**Fig 3.1 Cylindrical pressure vessel Model**

## MODEL & MESHING INTRODUCTION TO FINITE ELEMENT METHOD

The finite element method is a numerical procedure for analyzing structures and continua. Usually problem addressed is too complicated to solve satisfactorily by classical analytical methods. The finite element procedure develops many simultaneous algebraic equations, which are generated and solved on a digital computer. The results obtainable are accurate enough for engineering purposes at reasonable cost. In addition it is an efficient design tool by which designers can perform parametric design studies by considering various design cases (different shapes, materials, loads, etc.), analyze them and choose the optimum design. Hence the method has increasingly gained popularity among both researchers and practitioners.

## MESHING:

The Modeled cylinder was imported to ANSYS for meshing; The solid model was set element attributes, and established meshing controls, you can then turn the ANSYS program loose to generate the finite element mesh. By taking care to meet certain requirements, we can request a "mapped" mesh containing all quadrilaterals, all triangular, or all brick elements. Here the shell was meshed using quadrilateral elements. The mesh size used is 4mm for both shell and the stiffeners. The mesh size may be changed depending on the complexity of the problem. Also increases as the number of elements increases and it requires powered system to solve the problem. Mesh generation is one of the most critical aspects of engineering simulation.

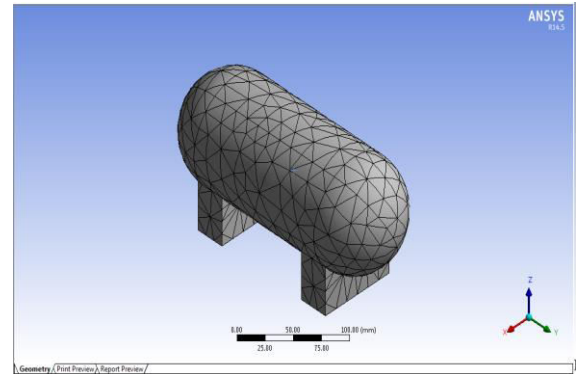

**Figure shows Mesh of the cylindrical pressure vessel**

## RESULTS

The analysis of Steel Cylindrical pressure vessel with the composite cylindrical pressure vessel is done. In addition we would like to change the orientation of composite cylindrical pressure vessel in such a way that the thickness is 1mm with variants of 7 layers, 8 layers, 9 layers and 10 layers of composite allowed with an angle of  $25^{\circ}$ ,  $35^{\circ}$ ,  $45^{\circ}$ ,  $55^{\circ}$ ,  $65^{\circ}$ ,  $75^{\circ}$  and  $90^{\circ}$ . The results for the composite pressure vessel of

1mm with 7 layers and different angles of orientation are as shown below:

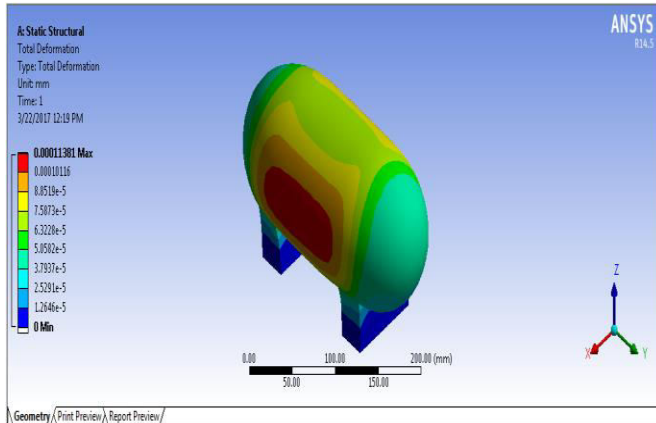

Figure 5.1 shows the Total deformation of the pressure vessel formed with stainless steel material

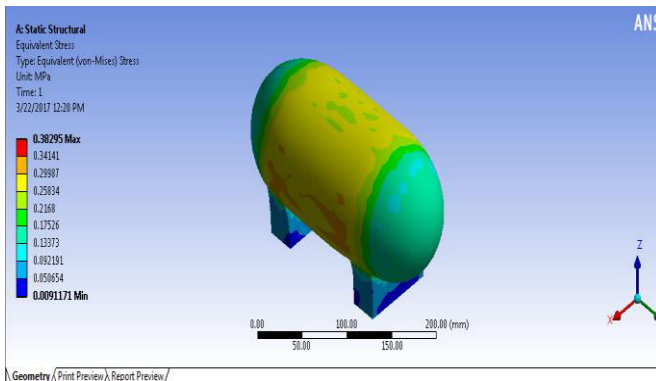

Figure 5.2 shows the equivalent stress analysis on pressure vessel of stainless steel material

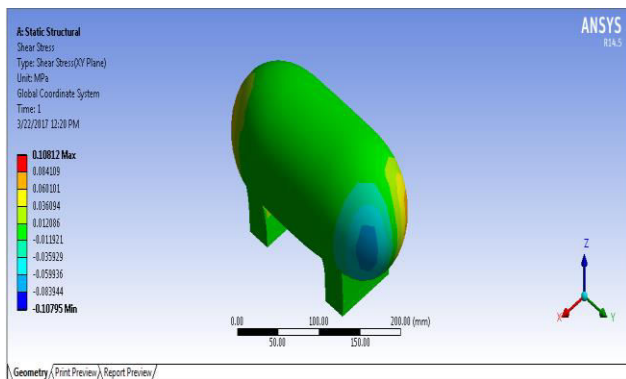

Figure 5.3 shows the shear stress of pressure vessel of stainless steel material

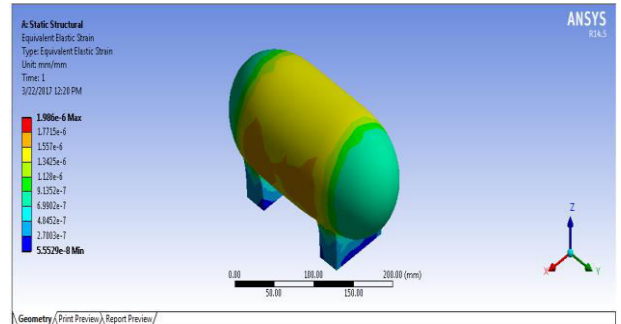
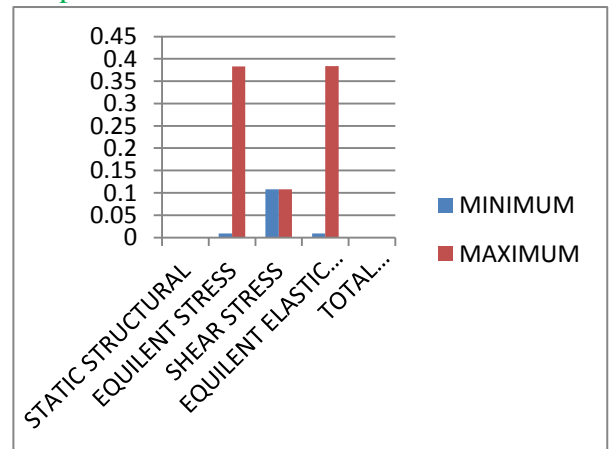

Figure 5.4 shows the Equivalent Elastic strain of pressure vessel of stainless steel material



Graph 5.1 maximum and minimum values of designed parameters

## CONCLUSIONS

This project work involves the comparison of conventional steel and Composite material cylindrical pressure vessel under static loading conditions the model is preferred of in Catia V5 R20 and then analysis is perform through ANSYS 15.0 from the result obtained it will be concluded that the development of a composite cylindrical pressure vessel having constant cross sectional area, where the stress level at any station in the Composite pressure vessel is considered drop and rise due to the orientation of composite, has proved to be very effective. Taking weight into consideration, we can conclude that 7layers gives lesser weight. But, taking stress and weight into consideration, 10layers is giving the desired result.





## REFERENCES

- [1] Rao Yarrapragada K.S.S, R.Krishna Mohan, B.Vijay Kiran, “Composite Pressure Vessels”, International Journal of Research in Engineering and Technology, Volume: 01 Issue: 04 | Dec-2012.
- [2] Mouritz. A.P., Gellert. E., Burchill. P and Challis. K., “ Review of advance composite structures for naval ship and submarines”, Composite structures, vol-53,pp 129-139 (1996).
- [3] Alexis A. Krikanov., “ Composite pressure vessels with higher stiffness” 1999 Elsevier science Ltd. Composite structures, vol-48, pp 119-127 (2000).
- [4] S. Adali, E.B. Summers & V.E. Verijenko., “Optimization of Laminated Cylindrical pressure vessels under strength criterion”, Composite structures, vol-25, pp 305-312 (1993), University of national Durban 4001, South Africa.
- [5] Tae-Uk Kim., Hvo-Chol Sin., “Optimal design of composite laminated plates with the discreteness in ply angles and uncertain in material properties considered”, Computers and Structures 79, pp 2501-2509, (2001).
- [6] Levend Parnas., Nuran Katirei., “Design of Fiber-Reinforced Composite pressure vessels under various loading conditions”, Composite structures 58, pp 83-95 (2002).