

## Implementation of Biomedical Device to Measure Heart Rate and Temperature

Uzma  
MTECH (student)  
SR. Engineering College  
Ananthasagar, Warangal.  
uzma454@gmail.com

K.Raj Kumar (Associate Professor)  
Department of ECE  
S.R. Engineering College  
Ananthasagar, Warangal.  
raj.kumar\_k@srecwarangal.ac.in

**Abstract**— This describes the design of a very low-cost biometric device which measures the heart rate and temperature of the subject by clipping sensors on one of the finger and then displaying the result on a text based LCD and continuously monitored using GSM modem even in remote areas. These devices are mostly used in hospitals and clinics but are gradually finding their way into domestic use. This demonstrates an approach to design a cheap, accurate and reliable device which can easily measure the heart rate and temperature of a human body.

**Keywords**— *Fingertip Sensor, Temperature Sensor, ARM7, Opamp, GSM modem.*

### I. INTRODUCTION

Heart rate is the number of heartbeats per unit of time, typically expressed as beats per minute (bpm). Heart rate can vary as the body's need to absorb oxygen and excrete carbon dioxide changes during exercise or sleep [1]. The measurement of heart rate and temperature is used by medical professionals to assist in the diagnosis and tracking of medical conditions. Heart rate measurement is one of the very important parameters of the human cardiovascular system. Electro-cardiogram (ECG) is one of frequently used and accurate methods for measuring the heart rate. ECG is an expensive device and its use for the measurement of the heart rate only is not economical [2]. The devices in the form of wrist watches are also available for the instantaneous measurement of the heart rate. Such devices can give accurate measurements but their cost is usually in excess of several hundred dollars, making them uneconomical. Most hospitals and clinics in the western countries use integrated devices designed to measure the heart rate, blood pressure, and temperature of the subject. Although such devices are useful, their cost is usually high and beyond the reach of individuals.



Figure 1. Patient monitoring system

Considering the above patient monitoring system is wired everywhere. The patient is monitored in ICU and the data transferred to the PC is wired. Such systems become difficult where the distance between System and PC is more and it is huge in size. Regular monitoring of patient is not possible once he/she is discharged from hospitals. These systems cannot be used at individual level. The other problem with these systems is that it is not capable of transmitting data continuously also range limitations of different wireless technologies used in the systems. So to overcome these limitations of systems, a new system has been proposed. This system is able to transmit the parameters of patient continuously and over long distance wirelessly. Due to which we would be able to attend the patient immediately. Therefore by developing a system that can constantly measure the important parameters of patient's body and which can alert the closed ones and the doctor on any time when the patient's condition gets bad, this can really provide quick service and be beneficial in saving a lot of lives. This device has the advantage that it is microcontroller based and thus can be programmed to display various quantities, such as the average, maximum and minimum rates over a period of time and so on. Another advantage of such a design is that it can be expanded and can easily be connected to a recording device or a PC to collect and analyses the data for over a period of time.

## II. PROPOSED BLOCK DIAGRAM

A fingertip sensor, which contains an IR light emitting diode and IR photo detector receiver used to measure the heart rate signal. After getting the signal, it must be amplified, because the signal amplitude is very low. This is done using amplifier circuit. Then the amplified signal is counted by the counter using microcontroller and temperature Sensor which is connected to microcontroller is used to measure temperature of the subject. Finally, the microcontroller analysis the data and result is displayed on LCD. Figure 2 shows the block diagram of the proposed design.

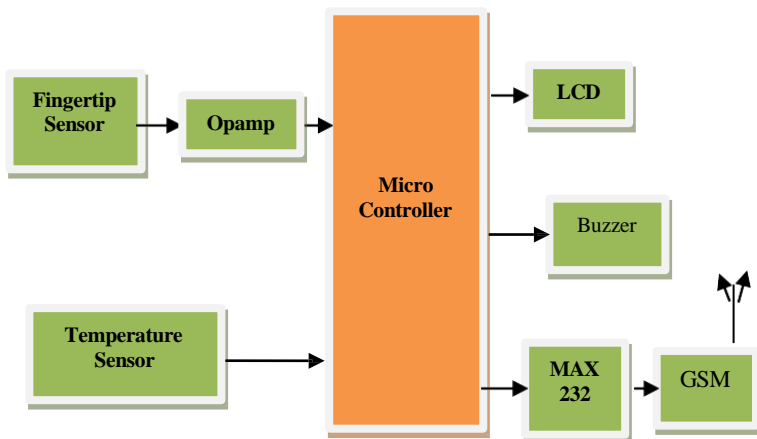

Figure 2. Block diagram of Heart rate and temperature measurement system

Using GSM modem message is transmitted to the programmed mobile number to the doctor in charge or close relatives when the measured temperature exceeds the allowable value or if the pulse measured is abnormal.

## III. PROPOSED CIRCUIT DESIGN

The heart rate and temperature measurement circuit consists of Fingertip Sensor, Temperature Sensor LM35, Opamp, ARM7, GSM modem.

### A. Fingertip Sensor and Opamp

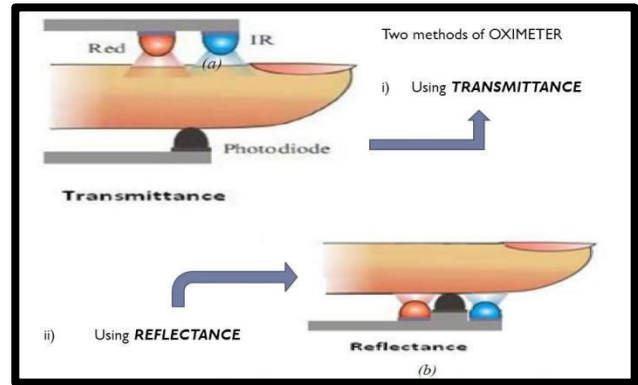

Figure 3. Transmittance (a) and Reflectance (b) configuration of Fingertip Sensor

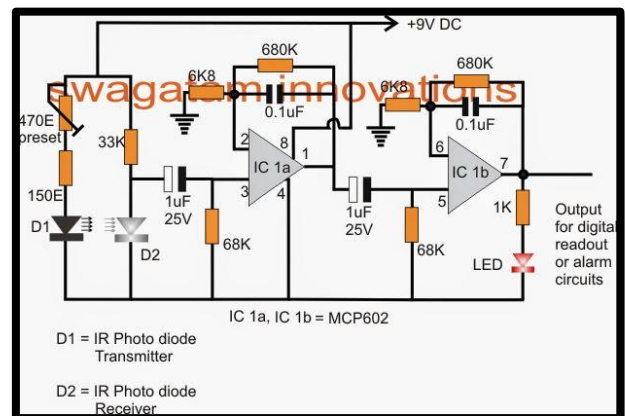

Figure 4. Schematic of heart rate conditioning circuit

Consider the figure 3, the sensor unit consists of an infrared light-emitting-diode (IR LED) and a photo diode, the fingertip is placed over the sensor assembly, as shown above. The IR LED transmits an infrared light into the fingertip, a part of which is reflected back from the blood inside the finger arteries. The photo diode senses the portion of the light that is reflected back. The intensity of reflected light depends upon the blood volume inside the fingertip. So, every time the heart beats the amount of reflected infrared light changes, which can be detected by the photo diode. With a high gain amplifier, this little alteration in the amplitude of the reflected light can be converted into a pulse. The reflected IR signal detected by the photo diode is fed to a signal conditioning circuit that filters the unwanted signals and boost the desired pulse signal. The signal conditioning circuit made of two stage operational

amplifiers configured as active low pass filters. The cut-off frequencies from both the filters are set to about 2.5 Hz, and so it can measure the pulse rate up to  $2.5 \times 60 = 150$  bpm[3]. The gain of each filter is about 101, which gives the total 2-stage amplification of about 10000. This is good enough to convert the weak pulsating signal into a TTL pulse. LED is connected at the output that will blink with heart beat.

## B. Temperature Sensor

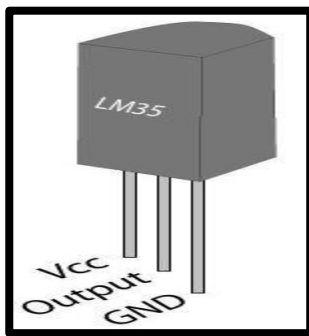

Figure 5. Temperature Sensor LM35

LM35 is a precision integrated temperature sensor whose output voltage is linearly proportional to the Celsius temperature. The LM35 does not require any external calibration or trimming to provide typical accuracies of  $\pm 1/4^\circ\text{C}$  at room temperature and  $\pm 3/4^\circ\text{C}$  over a full  $-55$  to  $150^\circ\text{C}$  temperature range. This is 3 legs IC that directly gives analog output. This unit requires +5VDC for its proper operation. LM35 is of low cost and well calibrated.

## C. ARM7(LPC2148)

LPC2148 microcontrollers are based on a 16-bit/32-bit ARM7TDMI-S CPU with real-time emulation and embedded trace support, that combine the microcontroller with embedded high-speed flash memory ranging from 32 kB to 512 kB. Due to their tiny size and low power consumption, LPC2148 are ideal for applications where miniaturization is a key requirement. Such as access control and point-of-sale. Serial communications interfaces ranging from a USB 2.0 Full-speed device, multiple UARTs, SPI, SSP to I2C-bus and on-chip SRAM of 8 KB up to 40 KB, make these devices very well suited for communication gateways. This unit is the heart of the complete system. It is actually responsible for all the process being executed. It will monitor & control all the peripheral devices or components connected in the system. In short we can say that the complete intelligence of the project resides in the software code embedded in the ARM 7. The

code will be written in Embedded C and will be burned or programmed into the code memory using a programmer.

## IV. DESIGN ALGORITHM

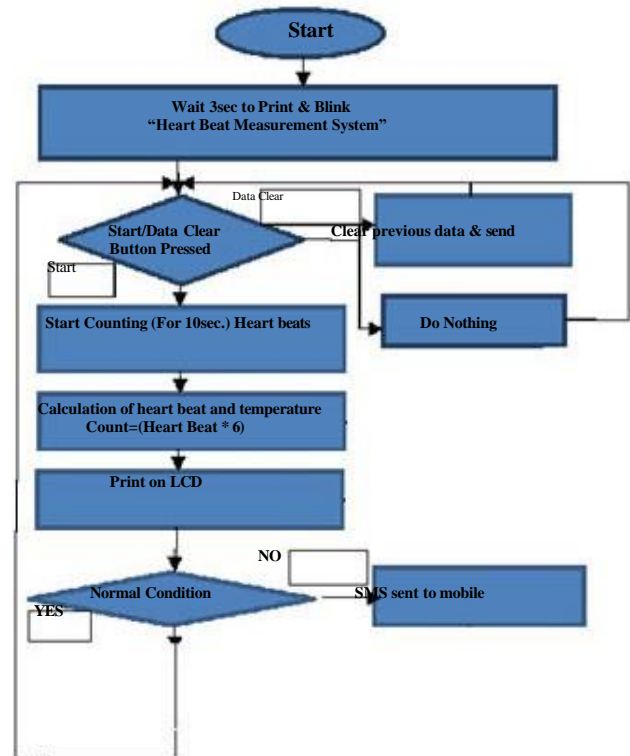

Figure 6. Flow chart

The steps taken for measuring the heart beat and temperature

- Device powered up and waited for 3 seconds so that in the meantime Display unit also turned on and showed blinking message in LCD display "Heart Beat Measurement System".
- Microcontroller will always check Start/Data Clear button is pressed or not. If nothing is pressed, the MCU will stay idle.
- If Start button is pressed then a high signal is passed to turn on the Sensor circuit and the counting takes place.
- After 10 sec counting and sensor circuit will be stopped.
- Counted values will be multiplied by 6 to get the average heart beat in a minute and this counted value and temperature value will be processed so that it can be displayed on LCD.

- If the measured heart beat and temperature is normal (normal range of Heart beat is 60-100 and temperature 98.6 F) than the circuit will be ready for next measurement.
- If not it give alarm indication and SMS will be transmitted to programmed mobile number.

## V. HARDWARE IMPLEMENTATION OF THE SYSTEM

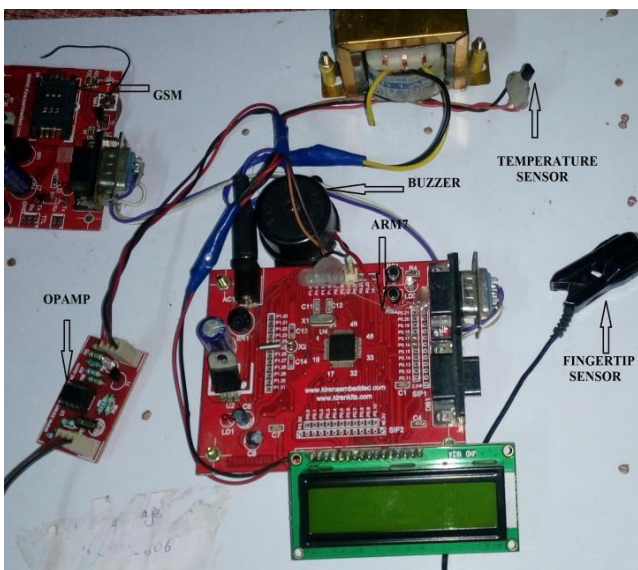

Figure 7. Implemented system for Heart rate and temperature measurement

The implemented circuit is as shown in figure 7, these figure show all the circuit components which are required to monitor the patient remotely. It consists of the sensors which measures heartbeat and body temperature and are labeled accordingly in Figures 7. The use of this device is very simple. At first, the cord is connected to the dc power supply. Wait for the device to be ready, when the device is ready, put your index finger on the heartbeat sensor and the LM35 sensor as shown in figure 9. wait for 10sec the result will be displayed on LCD.

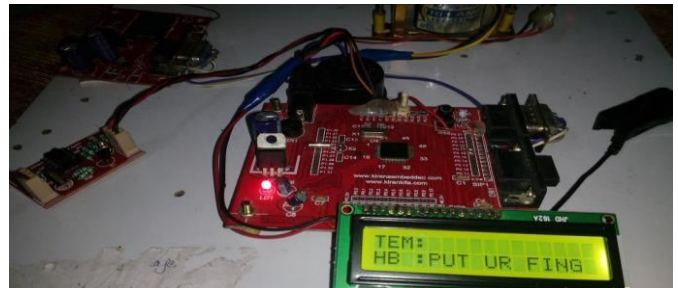

Figure 8. Implemented circuit (Ready to measure)

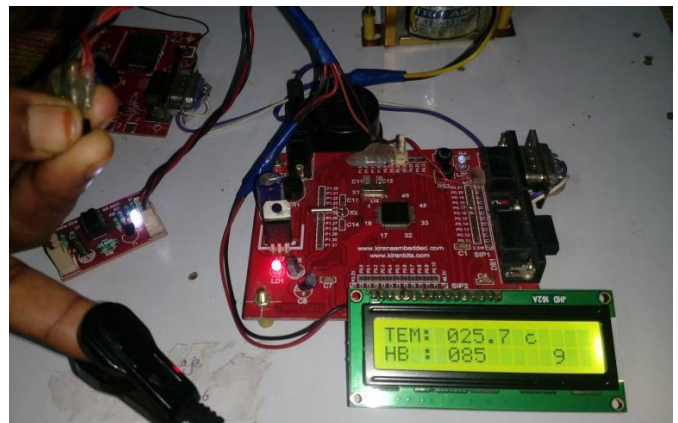

Figure 9. Implemented circuit (Showing output)

Figure 10. Shows, the measured heart rate and body temperature are sent to programmed mobile in abnormal condition.



Figure 10. Implemented circuit (Showing sending SMS)



Figure 11. Implemented circuit (Showing confirmation of SMS sent)

- [4] K.Ramesh, S.V.Aswin Kumer, “ Efficient health monitoring system using sensor networks”, International Journal of Scientific & Engineering Research Volume 3, Issue 6, June-2012.
- [5]. T. Wellem and B. Setiawan, “A Microcontroller-based Room Temperature Monitoring System”, International Journal of Computer Applications, vol. 53, (2012).

## VI. APPLICATIONS AND FUTURE CHALLENGES

### A. Applications

- This device can be used in home and hospital for patients or old person.
- In fitness center.
- In rural areas where medical facilities are limited.

### B. Future Challenges

This project can be implemented further as complete health monitoring system by measuring Blood Pressure, Tumors, diabetics etc. which can be done by connecting corresponding sensors to the MCU. Serial output can be attached to the device so that the measured values can be sent to a PC for further online or offline analysis. Using GPS the position of patient can be detected so that help can be provided in case of emergency from nearest hospital.

## VII. CONCLUSION

This paper led to the development of a system which measured heart beat and temperature of a patient based on microcontroller and information is sent to the concern person using GSM modem. It uses wireless communication to send the data which provides a greater mobility to the device. The cost is also minimized by utilizing the feature of sending multiple parameters via a single SMS.

### References

- [1] How the Heart Works, December 26, 2011.  
Available:<http://www.webmd.com/heartdisease/guide/how-heartworks>
- [2] John R. Hampton, “The ECG in Practice”
- [3] Heart rate measurement from finger trip. Available:  
<http://embedded-lab.com/blog/?p=1671>



# International Journal for Innovative Engineering and Management Research

*A Peer Reviewed Open Access International Journal*

[www.ijiemr.org](http://www.ijiemr.org)