



COPY RIGHT

2017 IJIEMR. Personal use of this material is permitted. Permission from IJIEMR must be obtained for all other uses, in any current or future media, including reprinting/republishing this material for advertising or promotional purposes, creating new collective works, for resale or redistribution to servers or lists, or reuse of any copyrighted component of this work in other works. No Reprint should be done to this paper, all copy right is authenticated to Paper Authors

IJIEMR Transactions, online available on 13th July 2017. Link :

<http://www.ijiemr.org/downloads.php?vol=Volume-6&issue=ISSUE-5>

Title: Smooth Mode Transfer In Micro grid Application Using Fuzzy Logic Control.

Volume 06, Issue 05, Page No: 1764 - 1770.

Paper Authors

* **DAVALA PRAVALLIKA, GAYATRI BUDDHARAJU.**

* Dept of EEE, Sri Sivani Institute of Technology.



USE THIS BARCODE TO ACCESS YOUR ONLINE PAPER

To Secure Your Paper As Per **UGC Guidelines** We Are Providing A Electronic Bar Code

SMOOTH MODE TRANSFER IN MICROGRID APPLICATION USING FUZZY LOGIC CONTROL

***DAVALA PRAVALLIKA, **GAYATRI BUDDHARAJU**

*PG Scholar, Dept of EEE, Sri Sivani Institute of Technology, Chilakapalem;
Srikakulam (Dt); A.P, India.

**Assistant Professor, Dept of EEE, Sri Sivani Institute of Technology, Chilakapalem;
Srikakulam (Dt); A.P, India.

valli2k9@gmail.com

gayatri205@gmail.com

ABSTRACT:

In recent years worldwide, there is considerable focus on the growth of renewable energy sources (RESs) and distributed generation system (DGs) leading to the concept of microgrid (MG), which is becoming increasingly very popular. The RESs, constituting a MG, by nature have intermittent power output. The main objective of this paper is smooth mode transfer in smart microgrid application is presented to distributed energy resource converter with utility grid. The proposed grid can operate in both standalone and grid connected mode. Fuzzy controller is used for smooth power transfer. The fuzzy logic controller is replaced by proportional integral (PI) controller for obtaining fast dynamic response, low steady error and for stable operation of the grid. The system performance is analyzed by using MATLAB/SIMULINK software.

Keywords: Smooth mode transfer, Voltage source, Microgrid, Fuzzy Logic Controller

I. INTRODUCTION

As fossil fuel supply becomes steadily tighter and electricity demand continues to grow, distributed generation technology based on renewable energy are beginning to attract wide attention. Distributed generation will undoubtedly be strong complement and effective support to bulk power grids, and be a trend of future power system development [1] [2]. To give full play to the advantages of distributed power generation technology, one or more distributed power (DG), energy storage device and controllable load form a micro-grid according to certain topological structure. Grid-connected mode is when micro-grid is connected to the main grid and island mode is when micro-grid is isolated from the main grid. Both are normal operation status of micro-grid. Proper control strategy is key to the steady operation of micro-grid [3]-[4]. Micro-grid smooth switchover between grid connected

mode and island mode is the emphasis and difficulty of micro-grid control strategy research and is important for steady operation and reliable power supply of micro-grid. A micro grid is a part of distribution network that includes multiple loads and distributed energy resource converters that are operated in parallel with the boarder utility grid [2]-[5]. It helps in integration of distributed energy resource converters to microgrid. Microgrid is a part of distributed generation system. It is a localized grouping of electricity generation, energy storage and loads that normally operate connected to a traditional centralized utility grid. The components of microgrid involve distributed generation resources such as photovoltaic panels, small wind turbines, fuel cells, etc. The storage devices are batteries, super capacitors, flywheel etc along with local loads. Better efficiency, superior quality with high reliability of power supply having environmental as well as economical benefits

can be achieved by using microgrid. A droop control is a control technique applied to distributed generation system for primary frequency control and as well as voltage control for load sharing between local loads to utility Grid. By controlling the frequency, as well as voltage, corresponding active power (P) and reactive power (Q) can be controlled in distributed generation. Increase in active power output results in reduction of frequency and the corresponding increase in the reactive power results in decrease of voltage as explained in [6]. The concept of Phase Locked Loop (PLL) is used for the implementation of grid synchronization method. PLL is used for the estimation of grid voltage, phase angle and frequency. A PLL is a control system in which output signal is generated by relating its phase to the phase of an input signal. A PLL can track an input frequency or it can generate a frequency that is a multiple of the input frequency as explained in [7]-[8].

This paper a fuzzy logic controller based smooth mode transfer in smart microgrid method is proposed for achieving the grid synchronization in terms of frequency, phase angle, amplitude of output voltages, active power and reactive power in between converter output and Distributed Energy Resource Converters (DERCs).

II. STRUCTURE OF MICROGRID SYSTEM

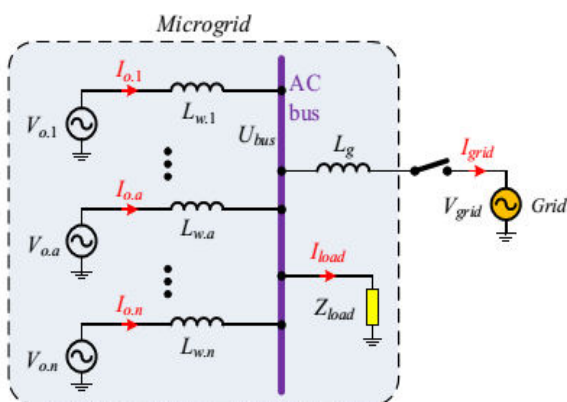

Fig.1. Diagram of microgrid system

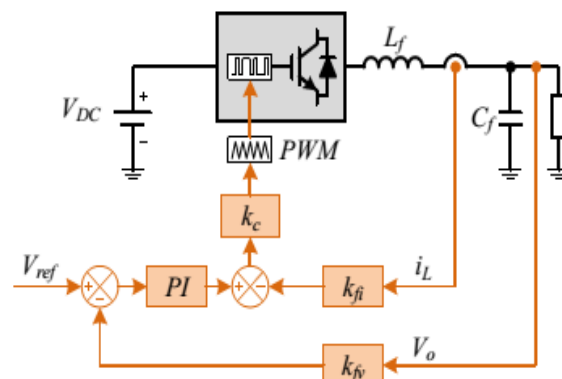

Fig.2. Control method of output voltage

Fig.1 expresses the diagram of microgrid system, which consists of n voltages-source inverters. The letter “a” represents any inverter in the system. $V_{o,a}$ and $I_{o,a}$ is the output voltage and current of any inverter respectively, $L_{w,a}$ is the wire inductor between the inverter and AC bus, which comply with the relation of (1).

$$k_a \cdot L_{w,a} = L_e \quad (a=1\dots n) \quad (1)$$

In this equation, k_a is the weighted coefficient of every inverter, which is related with the rated output power $S_{R,a}$ SR.a of every inverter, as shown in (2).

$$k_a = \frac{S_{R,a}}{\sum_{j=1}^n S_{R,j}} \quad (2)$$

In the microgrid, every VSI inverter will work as a robust voltage source and use the same control method of output voltage, whatever in GTM or ILM. The voltage control method is presented as shown in 0. The only difference of GTM and ILM is how to regulate the reference voltage V_{ref} of every inverter.

III. CONTROL STRATEGY IN GRID-TIED MODE

The principle of grid-tied control strategy of VSI in GTM can be described as Fig.3. And the control equation of every inverter is presented as (3).

$$\begin{cases} \omega_{a,k} = \omega_{a,k-1} - m_{\omega,a} (P_{o,a,k-1} - P_{ref,a,k-1}) \\ V_{a,k} = V_{a,k-1} - n_{v,a} (Q_{o,a,k-1} - Q_{ref,a,k-1}) \end{cases} \quad (3)$$

In this equation, the letter k and k-1 represents the kth and (k-1)th control cycle, ω_a and V_a is the angular frequency and amplitude of the inverter's voltage. Meanwhile, $\omega_{0,a}$ and $V_{0,a}$ is the initial value of ω_a and V_a when k equals to 0, and the initial value is defined as the rated angular frequency ω_r and the rated amplitude V_r .

Moreover, $P_{o,a}$ and $Q_{o,a}$ is the actual active and reactive output power of VSI, $m_{\omega,a}$ and $n_{v,a}$ is the droop control coefficient of $P_{o,a}$ and $Q_{o,a}$ which complies with the relation of (4). $P_{ref,a}$ and $Q_{ref,a}$ is the assigned active and reactive power of VSI injected to the grid which is determined by itself.

$$\begin{cases} m_{\omega,a} \cdot k_a = m_{\omega,c} \\ n_{v,a} \cdot k_a = n_{v,c} \end{cases} \quad (a = 1 \dots n) \quad (4)$$

The FFT module is used to analyze the harmonic components of grid voltage. Based on the results of FFT module, the harmonic compensation module will calculate the harmonic reference voltage $V_{ref,H}$ to simulate the harmonics of grid, which is used to eliminate the harmonic current injected into the grid. In the harmonic compensation, only the low frequency odd harmonics will be analyzed, such as 3rd - 9th odd harmonics, and the high-frequency harmonics will be ignored.

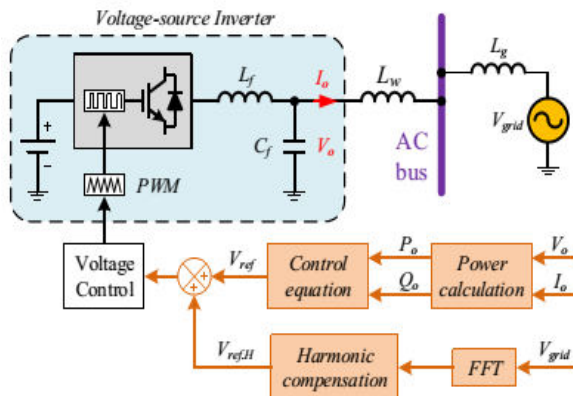

Fig.3. control strategy of vsi in gtm

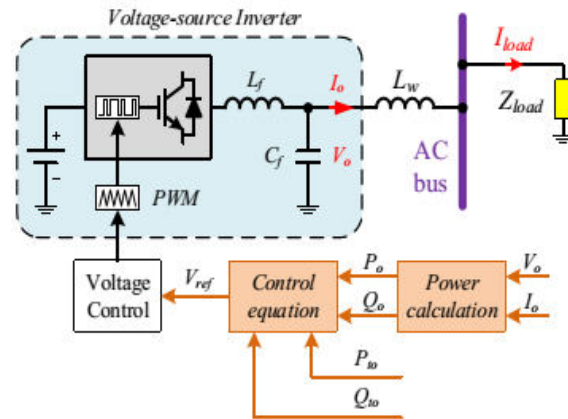

Fig.4. Control strategy of VSI in ILM

IV. CONTROL STRATEGY OF ISLANDING MODE

The principle of islanding control strategy can be described as Fig.4, which is proposed. The control equation of every inverter is presented as (5), which is analogous to (3). In this equation $m_{\omega,a}$ and $n_{\omega,a}$ also complies with the relation as shown in (4).

$$\begin{cases} \omega_{a,k} = \omega_r - m_{\omega,a} (P_{o,a,k-1} - P_{ref,a,k-1}) \\ V_{a,k} = V_{a,k-1} - n_{v,a} (Q_{o,a,k-1} - Q_{ref,a,k-1}) \end{cases} \quad (5)$$

The major difference of (3) and (5) is, (5) replace $\omega_{a,k-1}$ with the rated angular frequency ω_r . The reason is that, the AC bus voltage U_{bus} is controlled by grid in GTM, and controlled by SIs in ILM. Therefore, every VSI should track the frequency of grid In GTM, which has a certain variation range. While in ILM, every VSI should have a fixed frequency reference to sustain U_{bus} stable.

Moreover, $P_{ref,a}$ and $Q_{ref,a}$ in ILM is determined by the load sharing of microgrid, which is calculated by (6). Therefore the realization of (6) needs communication among VSIs to analysis the active and reactive power of the whole microgrid system.

$$\begin{cases} P_{ref,a} = k_a \cdot P_{to} = k_a \sum_{j=1}^n P_{o,j} \\ Q_{ref,a} = k_a \cdot Q_{to} = k_a \sum_{j=1}^n Q_{o,j} \end{cases} \quad (6)$$

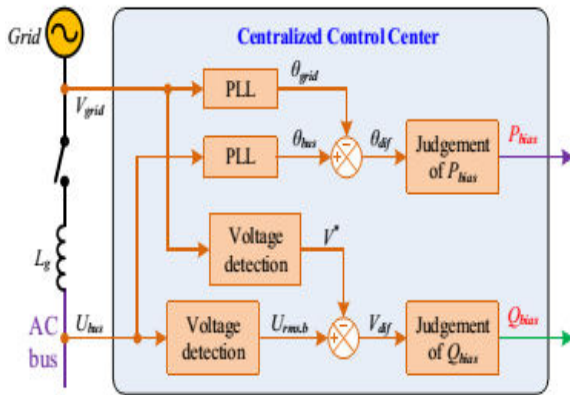

Fig.5. Grid-tracking control strategy

V. GRID-TRACKING CONTROL STRATEGY

The AC bus voltage U_{bus} of microgrid should be synchronized with the grid voltage V_{grid} before microgrid switches from ILM to GTM. In this paper, a grid-tracking control strategy is proposed to solve this problem. This method works as an additional loop of the control strategy of ILM to ensure U_{bus} has the same amplitude, phase and frequency with V_{grid} , and it will be deactivated when the grid is abnormal or unavailable. The proposed grid-tracking method is realized by introducing the bias power P_{bias} and Q_{bias} in (5), which is shown as (7). And the diagram of this method can be presented as shown in Fig.5.

$$\begin{cases} \omega_{a,k} = \omega_r - m_{\omega,a}(P_{o,a,k-1} - P_{ref,a,k-1}) - m_{\omega,a}k_a \cdot P_{bias,k-1} \\ V_{a,k} = V_{a,k-1} - n_{v,a}(Q_{o,a,k-1} - Q_{ref,a,k-1}) - n_{v,a}k_a \cdot Q_{bias,k-1} \end{cases} \quad (7)$$

In this method, a centralized control center (3C) is used to measure and analyze the voltages of AC bus and grid, and send the same P_{bias} and Q_{bias} to every VSI. The principle of phase tracking and voltage tracking can be presented by Fig.6 and Fig.7.

As shown in the two figures, when the grid is normal, 3C will calculate the phase difference θ_{dif} and amplitude difference V_{dif} of U_{bus} and V_{grid} . Subsequently, P_{bias} and Q_{bias} will be assigned a fixed value respectively according to the polarity of θ_{dif} and V_{dif} . The fixed value should guarantee

U_{bus} can synchronize with V_{grid} during a given period, and avoid the voltage jump of U_{bus} . When the grid is abnormal or unavailable, 3C will assign 0 to P_{bias} , so every VSI can control freely its own frequency around the rated angular frequency ω_r . Meanwhile, 3C will calculate the amplitude difference of U_{bus} and the rated value V_r and guarantee the amplitude of U_{bus} in a reasonable range by Q_{bias} .

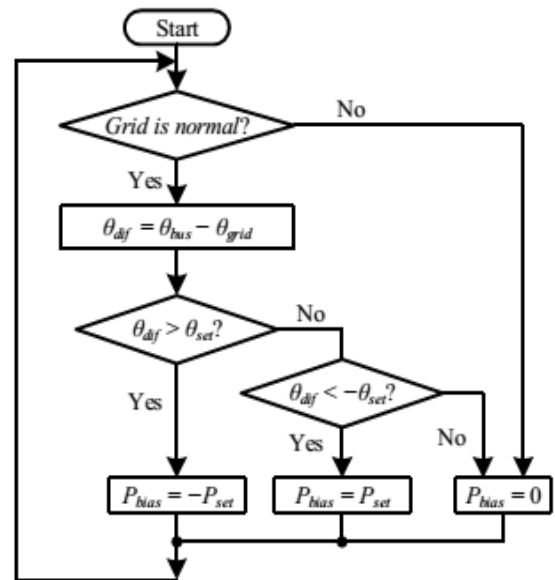

Fig.6. Control method of phase tracking

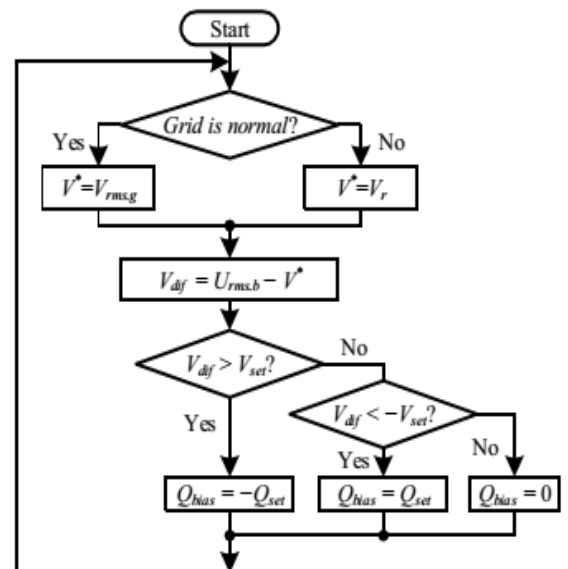

Fig.7. Control method of amplitude tracking

VI. FUZZY LOGIC CONTROLLER

The Fuzzy control is a methodology to represent and implement a (smart) human's knowledge about how to control a system. A fuzzy controller is shown in Figure.8. The fuzzy controller has several components:

- A rule base that determines on how to perform control
- Fuzzification that transforms the numeric inputs so that the inference mechanisms can understand.
- The inference mechanism uses information about the current inputs and decides the rules that are suitable in the current situation and can form conclusion about system input.
- Defuzzification is opposite of Fuzzification which converts the conclusions reached by inference mechanism into numeric input for the plant.

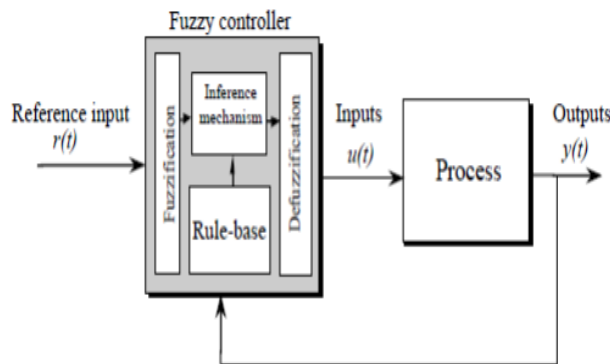

Fig.8 Fuzzy Control System

Fuzzy logic is a form of logic that is the extension of boolean logic, which incorporates partial values of truth. Instead of sentences being "completely true" or "completely false," they are assigned a value that represents their degree of truth. In fuzzy systems, values are indicated by a number (called a truth value) in the range from 0 to 1, where 0.0 represents absolute false and 1.0 represents absolute truth. Fuzzification is the generalization of any theory

from discrete to continuous. Fuzzy logic is important to artificial intelligence because they allow computers to answer 'to a certain degree' as opposed to in one extreme or the other. In this sense, computers are allowed to think more 'human-like' since almost nothing in our perception is extreme, but is true only to a certain degree.

Table 1: IF-THEN rules for fuzzy inference system

u(t)	e(t)							
		NB	NM	NS	ZO	PS	PM	PB
Δe(t)	NB	NB	NB	NB	NB	NM	NS	ZO
	NM	NB	NB	NB	NM	NS	ZO	PS
	NS	NB	NB	NM	NS	NS	PS	PS
	ZO	NB	NM	NS	ZO	ZO	PM	PM
	PS	NM	NS	ZO	PS	PS	PB	PB
	PM	NS	ZO	PS	PM	PM	PB	PB
	PB	ZO	PS	PM	PB	PB	PB	PB

The fuzzy rule base can be read as follows
IF e(t) is NB and Δe(t) is NB **THEN** u(t) is NB
IF e(t) is <negative big> and Δe(t) is <negative big> **THEN** u(t) is <negative big>

VII. MATLAB/SIMULATION RESULTS

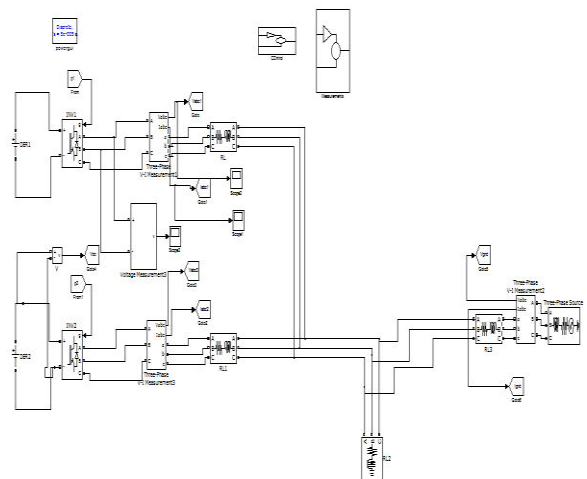

Fig.9. Matlab and Simulink Circuit diagram for GTM

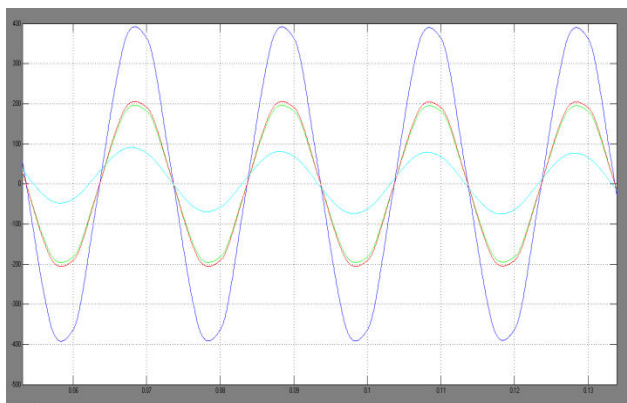

Fig.10. Simulation results for GTM Phase voltages (Vabc), Phase currents (Iabc1, Iabc2) and Grid current I grid

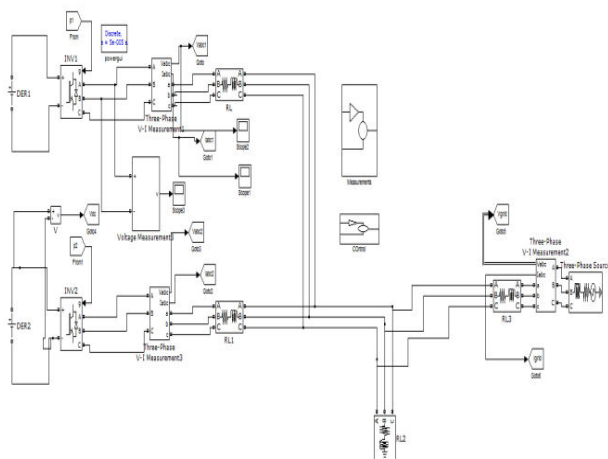

Fig.17. Matlab/Simulink Control circuit for fuzzy logic controller

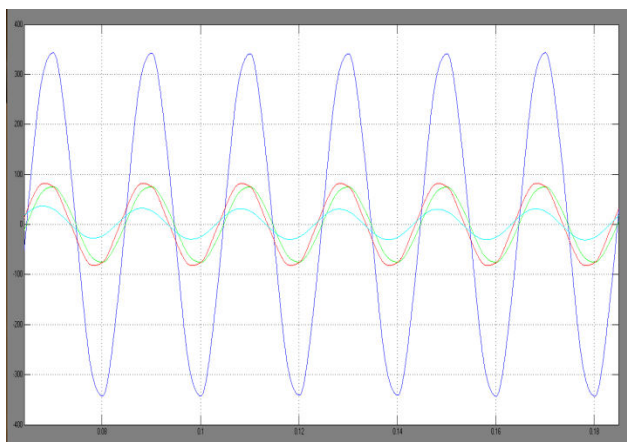
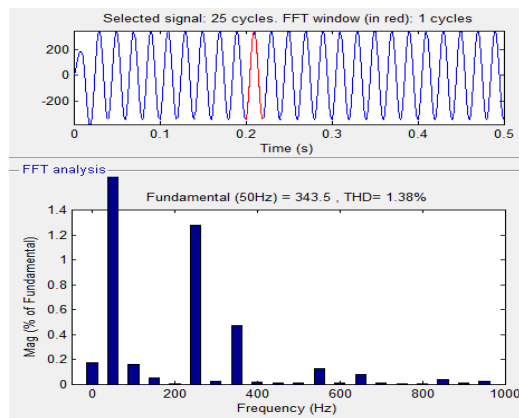
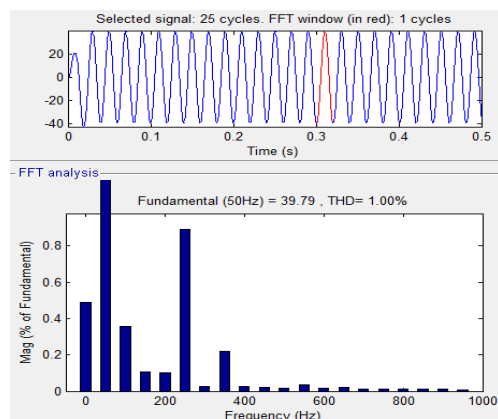

Fig.18. Simulation waveform of GTM with Fuzzy logic controller



(a) PI Controller



(b) Fuzzy logic controller

Fig.19. THD waveforms for the GTM with PI, Fuzzy controller

VIII. CONCLUSION

In this work a complete control system of smart microgrid is proposed in this project, in order to realize the smooth mode transfer of the GTM and ILM. A fuzzy logic based secondary controller is used for achieving the grid synchronization by integrating the distributed energy resource converters to microgrid. The simulation results with fuzzy logic controller helps in obtaining the quick response, low steady state error and reduces the harmonics with low ripple content. The power factor is also improved near PCC and power quality has been increased by the influence of multiple types of DG sources in distribution generation system. The proposed GTM is further

implemented with fuzzy controller. By using this controller connected to GTM is compared and attained good results in case of THD is reduced and better results obtained for smooth mode transfer.

REFERENCES

- [1] D. Prasad rao, A. Ravi Kumar and T. Giri Babu, "Enhancement of Microgrid Control In Distribution System Using Fuzzy Logic Technique," International Journal of Advanced Technology in Engineering and Science, Vol. No.4, Issue No. 09, September 2016.
- [2] SolankeTirupati U, Kulkarni Anant A, "Effective Microgrid Synchronization in Islanded Mode: Controlled Input/output PI-Fuzzy-PI Algorithm," International Journal of Computer Applications (0975 – 8887) Volume 75 – No.16, August 2013.
- [3] Peng, F.Z., Yun Wei Li, Tolbert, L.M., "Control and protection of power electronics interfaced distributed generation systems in a customer driven microgrid," Power & Energy Society General Meeting, 2009. PES '09. IEEE, pp.1-8, 26-30 July 2009
- [4] Zhilei Yao, Lan Xiao, Yangguang Yan, "Seamless Transfer of Single Phase Grid-Interactive Inverters Between Grid-Connected and StandAlone Modes," Power Electronics, IEEE Transactions on , vol.25, no.6, pp.1597-1603, June 2010
- [5] J.M. Guerrero, Loh P C, Tzung-Lin Lee, MukulChandorkar, "Advanced control architectures for intelligent microgrids—Part II: Power quality, energy storage, and AC/DC microgrids," Industrial Electronics, IEEE Transactions on, 2013, 60(4): 1263-1270.
- [6] Mingzhi Gao, Canhui Zhang, MaohangQiu, Weiheng Li, Min Chen, Zhaoming Qian, "An accurate power-sharing control method based on circulating-current power model for voltage-source-inverter parallel system," 2015 IEEE APEC, pp.1815-1821, 15-19 March 2015
- [7] Yunwei Li, D.M. Vilathgamuwa, Poh Chiang Loh, "Design, analysis, and real-time testing of a controller for multi bus microgrid system," Power Electronics, IEEE Transactions on , vol.19, no.5, pp.1195-1204, Sept. 2004
- [8] Yang Fu, Lisha Huang, Jingjing Zhao, "Micro-Grid Smooth Switchover Method Based on Controller State Following," Journal of Power and Energy Engineering, 2015, 3, 128-135.