

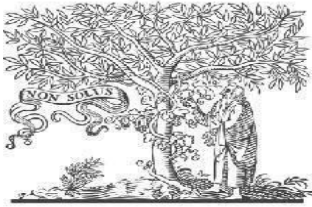

**COPY RIGHT**



**ELSEVIER**  
**SSRN**

**2021IJIEMR.** Personal use of this material is permitted. Permission from IJIEMR must be obtained for all other uses, in any current or future media, including reprinting/republishing this material for advertising or promotional purposes, creating new collective works, for resale or redistribution to servers or lists, or reuse of any copyrighted component of this work in other works. No Reprint should be done to this paper, all copy right is authenticated to Paper Authors

IJIEMR Transactions, online available on 20<sup>th</sup> Sep 2016.

Link : <https://ijiemr.org/downloads/Volume-05/Issue-07>

**Title: Power Quality Improvement in DFIG based Microgrid using ANN Controller**

volume 05, Issue 07, Pages: 22-30

Paper Authors : <sup>1</sup>Ms.O.Prameela Rani, <sup>2</sup>Mr.B.Thiraviam,



USE THIS BARCODE TO ACCESS YOUR ONLINE PAPER

## Power Quality Improvement in DFIG based Microgrid using ANN Controller

<sup>1</sup>Ms.O.Prameela Rani, <sup>2</sup>Mr.B.Thiraviam,

<sup>1,2</sup> Assistant Professor, Dept. of CSE,

Malla Reddy Engineering College (Autonomous), Secunderabad, Telangana State

### Abstract:

This paper presents the power quality analysis of microgrid. The Hybrid system is a combination of PV, DFIG-Wind and Battery systems. Here, three various system of micro-grid are taken namely, PV-Battery system, DFIG system, Hybrid system to show the importance of DFIG and its in-built converters. The DFIG is a set of Grid and Rotor side converters. All the three systems are to be model and simulate in Matlab. The Grid Side Converter (GSC) of DFIG also utilized as inverter of PV System which reduces the cost of one converter also improves the power quality and harmonic distortions. To improve the power quality of proposed grid side converter is to be implement with ANN controller.

### Introduction:

In the present scenario, maximum utilization of energy demand in the world is based on fossil fuels such as coal, natural gas and petroleum products. But, in this one of the major disadvantage from these products are global warming, and these result in great danger for life on the planet [1].

The alternative solution for this fossil fuels are utilization of renewable energy sources. The power generated by a wind energy system is depends on the climate conditions; for example, if in case of rainy or in case of cloudy conditions, it is not possible to meet the energy demand [2]. For flexible and reliable operation of the system, the best solution is to integrate the wind generation system with other renewable sources such as solar, electrolyzer, fuel cell or in some cases grid interconnection.

The capability of fuel cell power generation system, wind energy generation system and photovoltaic based hybrid system can be to overcome the inconvenience caused by the grid power system. Hence, in this paper the coordination of FC, Solar and wind generation system is considered for eliminating the fluctuations [3].

This simulation model is performed using Matlab and SimPower Systems and results are presented to verify the effectiveness of the proposed system [4]-[5]. The proposed grid connected hybrid energy generation system is shown in figure 1.

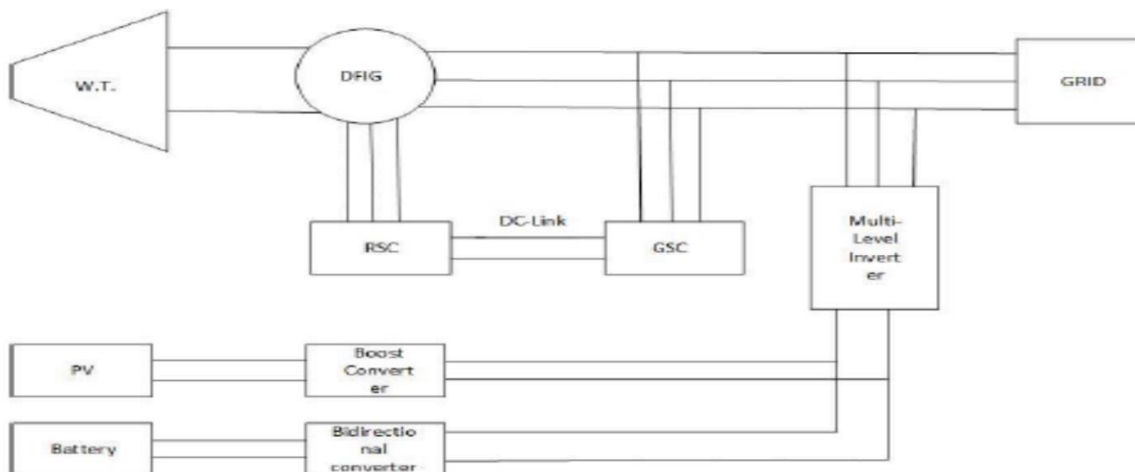

**Fig 1: Configuration of proposed grid connected hybrid system**

Figure 1 shows the configuration structure for hybrid system based fuel cell, solar and wind energy systems. The mechanical power captured from wind by a wind turbine can be formulated as [6]:

$$P_m = 0.5 \rho A C_p V^3$$

0.59 is the theoretical maximum value power coefficient value, It is based on two variables the pitch angle tip speed ratio (TSR). With respect to longitudinal axis turbine blades are aligned at an angle that is the pitch angle. The linear speed of the rotor to the wind speed is *TSR*.

Wind turbine “ $C_p$  Vs.  $\lambda$ ” curve is shown in Figure.2. In practical designs, 0.4 to 0.5 is the maximum achievable range for high speed turbines and for slow speed turbines it is in the range of 0.2 to 0.4. At  $\lambda_{opt}$  its maximum value ( $C_{pmax}$ ) is shown in Figure 2.

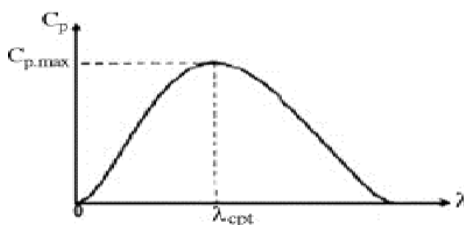

**Figure 2: Power coefficient Vs Tip Speed Ratio**

### MODELLING AND DESIGN OF DFIG:

The doubly fed induction generator is the better solution for variable speed machines with tolerance  $\pm 30\%$  of synchronous speed. The grid and the rotor are directly connected for the main stator winding is controlled with converters via slip rings as shown in Figure 3.

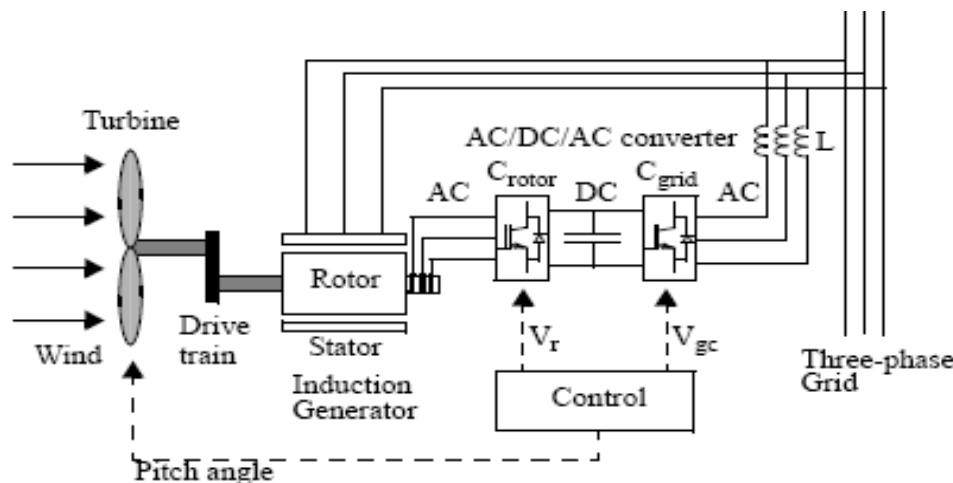

Figure 6: DFIG Connected to Wind Turbine

Figure 7 shows the overall RSC control scheme which is having two cascade loops.  $V_{dr0}$  and  $V_{qr0}$  are from the two regulated current controllers outputs. And these signals are used for generating Pulses to RSC converter by PWM technique.

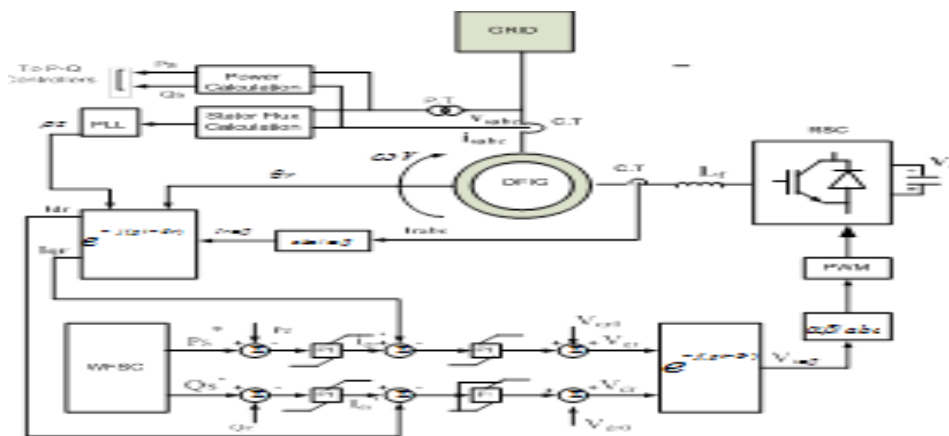

Figure 7: Control Diagram for the rotor side controller

## MODELING OF SOLAR SYSTEM:

In electrical phenomenon photovoltaic network, the cell is that the essential part. PV exhibit is nothing however sunlight based cells region unit associated non-concurrent or parallel for increasing required current, voltage and high power [9]. Each cell is practically identical to a diode with an intersection designed by semiconductor material. It delivers the streams once lightweight consumed at the intersection, by the electrical marvel sway. It are frequently seen that a most electric outlet exists on each yield power diagram 4. The Figure 8 shows the (I-V) and (P-V) characteristics of the PV exhibit [10] [12] at entirely unexpected star intensities.

$$I = I_{ph} - I_d - I_{sh}$$

$$I = I_{ph} - I_o[\exp(qV_d / nKT)] - (V_d / R_s)$$

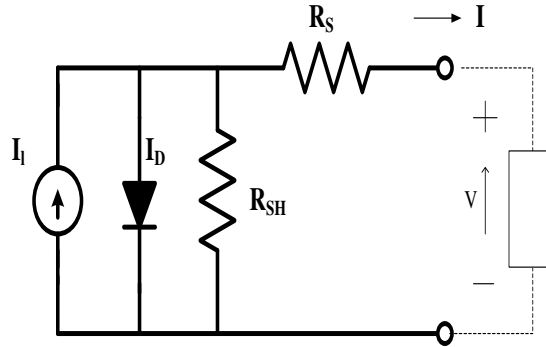

**Figure 8: Equivalent circuit of PV Module**

Power output of solar cell is  $P = V * I$

### Artificial Neural Networks:

The structure of an ANN, in which a circle indicates a fixed node, whereas a square indicates an adaptive node, is shown in Figure 9. In this structure, there are input and output nodes, and in the hidden layers, there are nodes functioning as membership functions (MFs) and rules. This eliminates the disadvantage of a normal feed forward multilayer network, which is difficult for an observer to understand or to modify. For simplicity, we assume that the examined FIS has two inputs and one output. In this network, each element of the input vector  $p$  is connected to each neuron input through the weight matrix  $W$ . The  $i$ th neuron has a summer that gathers its weighted inputs and bias to form its own scalar output  $n(i)$ . The various  $n(i)$  taken together form an  $S$ -element net input vector  $n$ .



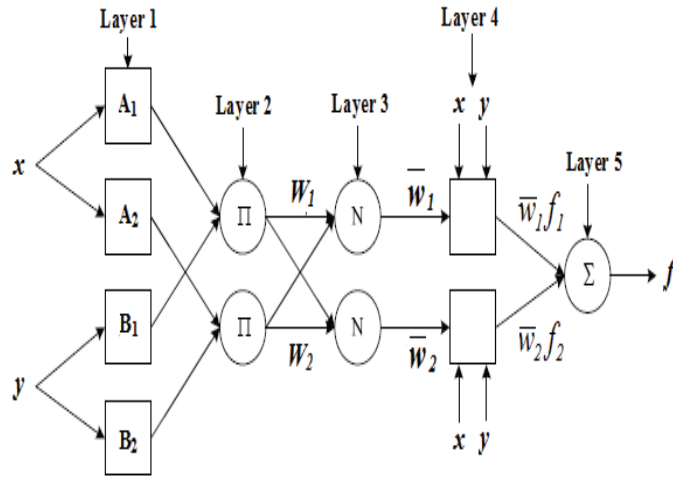

Figure 9: ANN architecture for a two-input multi-layer network

### Simulation Case Study:

In this section we have simulated three different microgrids namely PV-Battery system, DFIG system, Hybrid (PV, Wind, and Battery) system which is shown in figure 1.

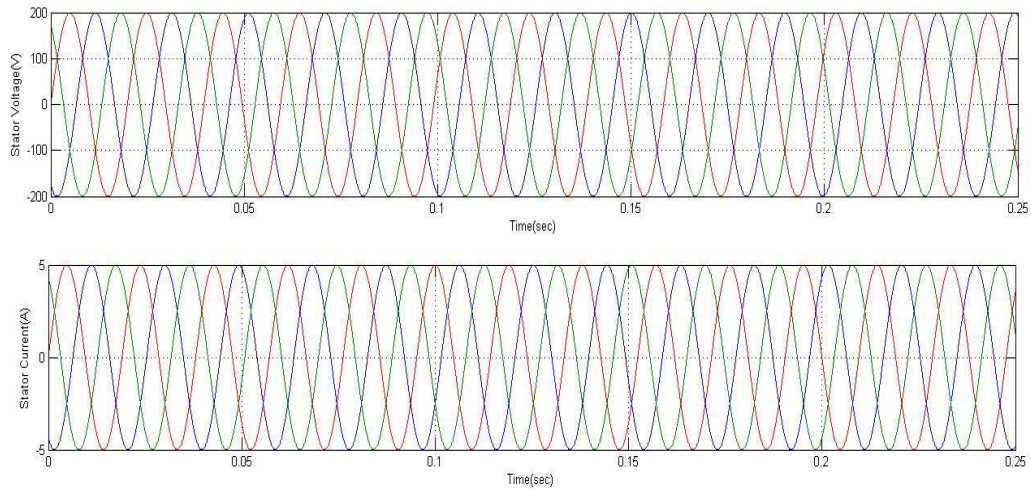

Figure 10: Simulation Result for Stator Voltage and Current Waveforms for DFIG System with PI Controller

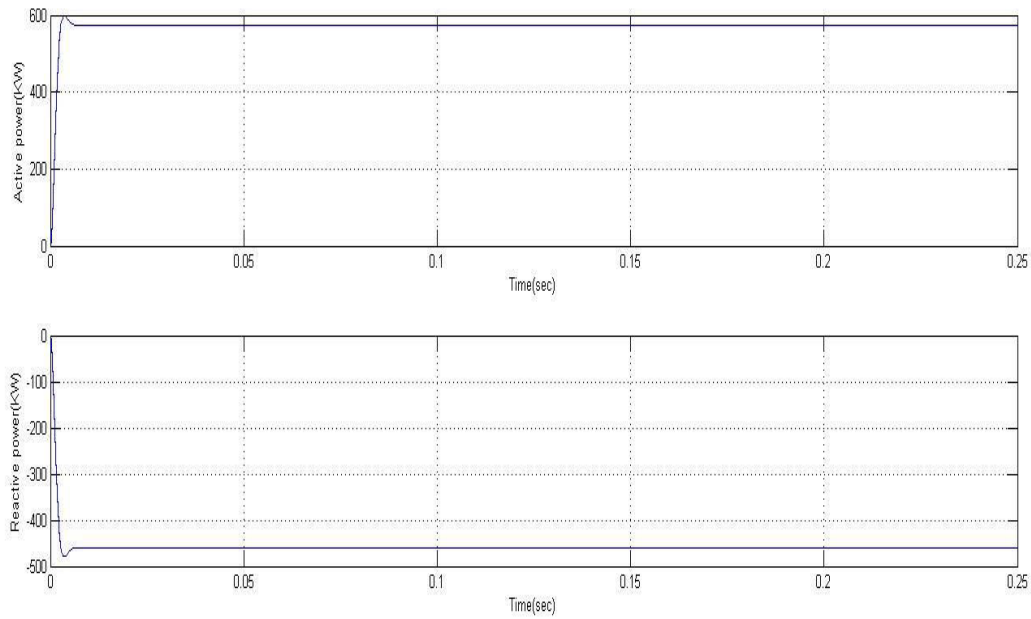

Figure 11: Simulation Result for DFIG Stator Powers with PI controller

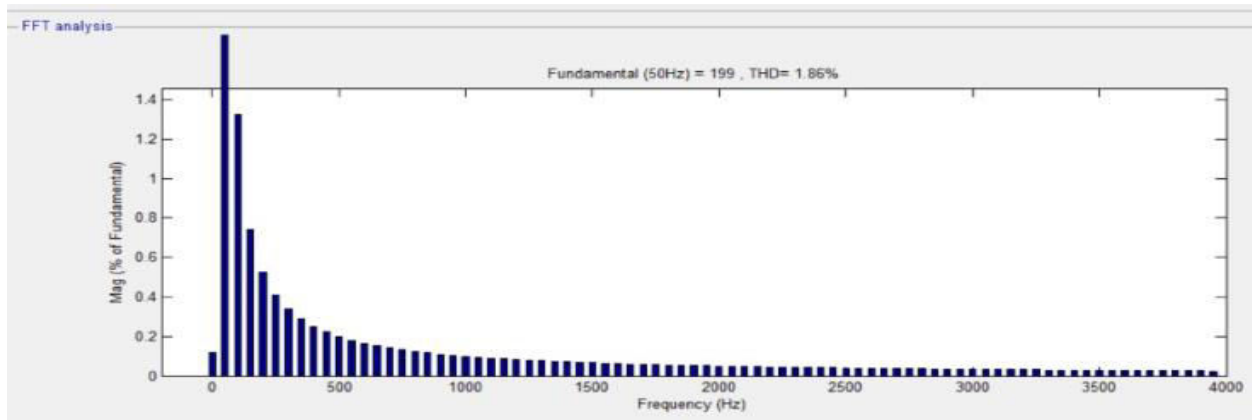

Figure 12: Voltage THD for DFIG with Conventional Controller

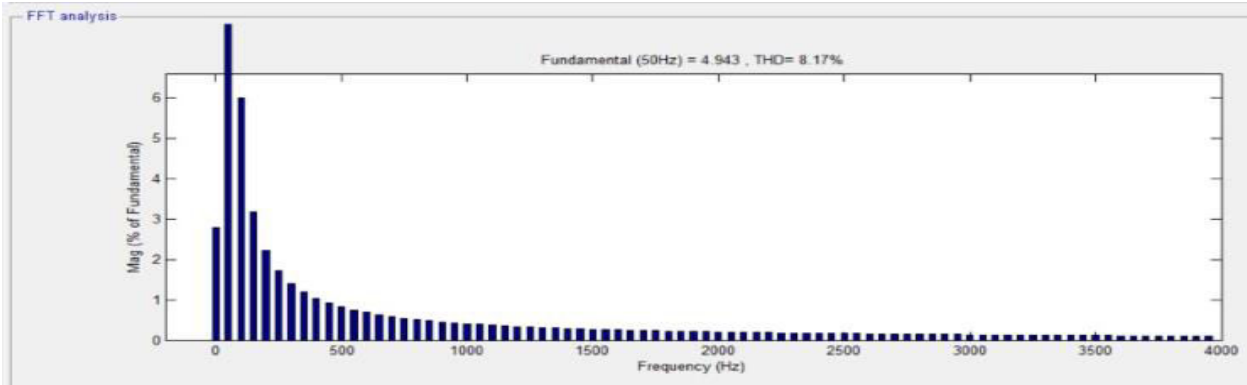

Figure 13: Current THD for DFIG with Conventional Controller

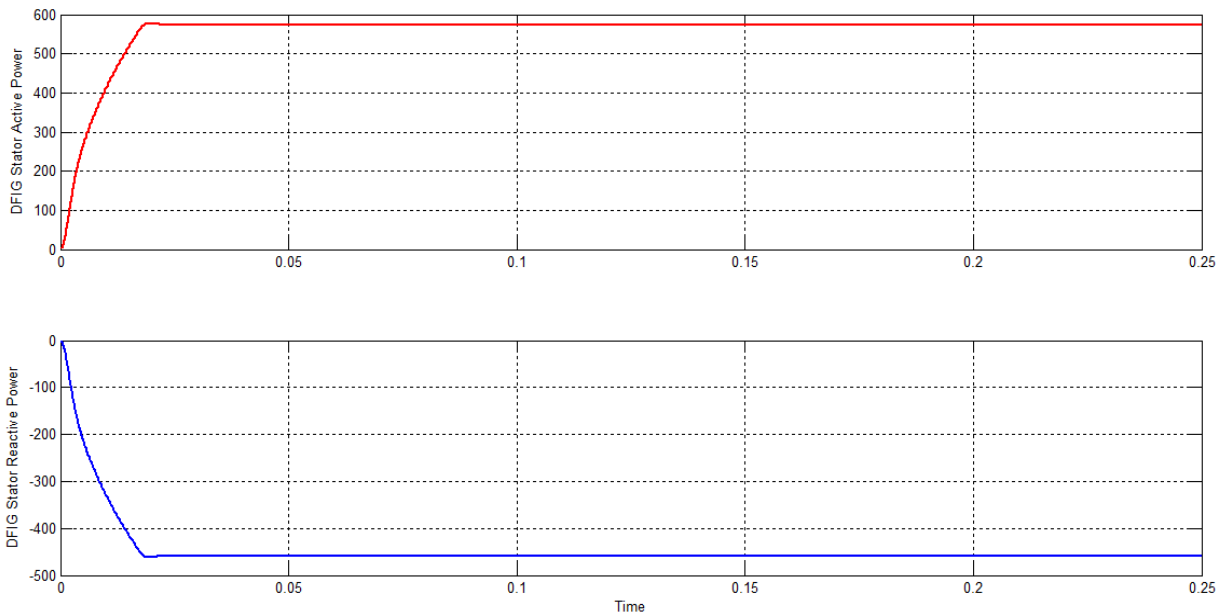

Figure 14: Simulation Result for DFIG Stator Powers with ANN controller



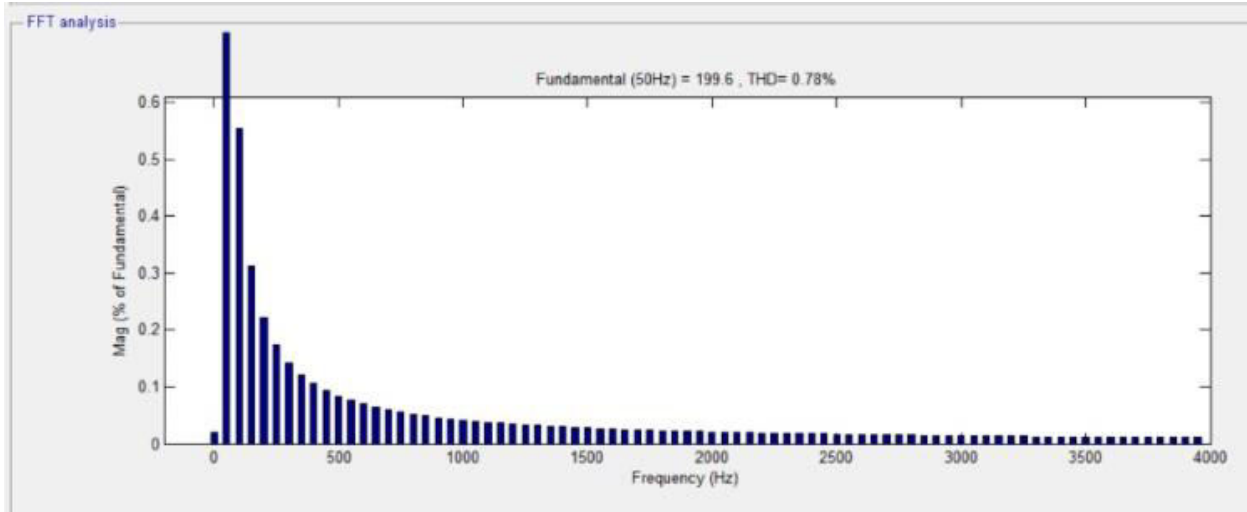

Figure 15: Voltage THD for DFIG with ANN Controller

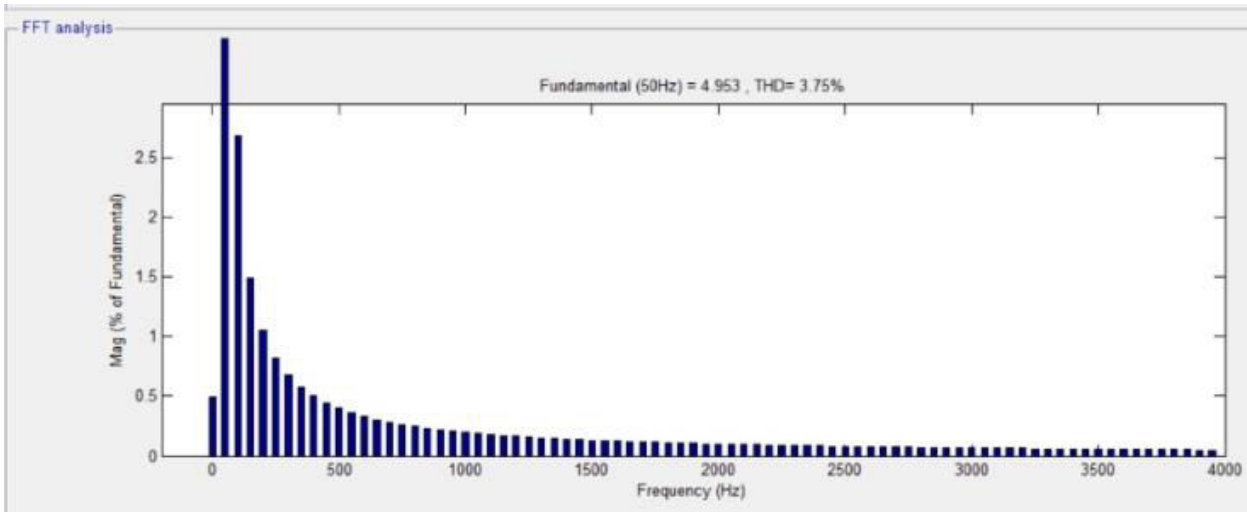

Figure 16: Current THD for DFIG with ANN Controller

## CONCLUSION

This paper proposes an application of ANN controller to RSC and GSC of DFIG converter provides better reduction of THD in hybrid system as comparative with MLI. It has been also proven that, the DFIG grid converter can also be used in PV-Battery system, which eliminate the need of converter in PV-Battery system and hence power quality is improved. The performance of ANN based DFIG Controller provides better performance as compared with Conventional Controller.

## REFERENCES

1. T. Ackermann, et al, Wind Power in Power Systems, John Wiley & Sons, 2005.



2. W. Qiao and R. G. Harley, "Grid connection requirements and solutions for DFIG wind turbines," in Proc. IEEE Energy 2030 Conference, Atlanta, GA, USA, Nov. 17-18, 2008.
3. C. Abbey and G. Joos, "Super capacitor energy storage for wind energy applications," IEEE Trans. Industry Applications, vol. 43, no. 3, 769- 776, May/June 2007.
4. T. Eswara Rao, **Krishna Mohan Tatikonda**, S. Elango, and J. Charan Kumar, "MICROGRID TECHNOLOGIES", Edited by C. Sharmeela, P. Sivaraman, P. Sanjeevikumar, and Jens Bo Holm-Nielsen, Scrivener Publishing, ISBN: 9781119710790.
5. C. Abbey and G. Joos, "Integration of energy storage with a doubly-fed z.1, induction machine for wind power applications," Proceedings of IEEE Power Electronics Specialists Conference, PESC 04, vol. 3, pp. 1964-1968, June 2004.
6. R. Pena, J. C. Clare, and G. M. Asher, "Doubly fed induction generator using back-to-back PWM converters and its application to variable speed wind-energy generation," Proc. Inst. Elect. Eng., vol. 143, no. 3, pp. 231–241, May 1996.
7. W. Leonhard, Control of Electrical Drives, Springer, 3rd ed., 2001.
8. Petersson, L. Harnefors, and T. Thiringer, "Evaluation of current control methods for wind turbines using doubly-fed induction machines," IEEE Trans. Power Electron., vol. 20, no. 1, pp. 227–235, Jan. 2005.
9. Petersson, "Analysis, Modelling, and Control of Doubly-Fed Induction Generators for Wind Turbines," Ph.D. dissertation, Chalmers Univ. Technol., Goteborg, Sweden, 2005.
10. Krishna Mohan Tatikonda, Udaya K. Renduchintala, Chengzong Pang, and Lin Yang, " ANFIS-fuzzy logic based UPQC in interconnected microgrid distribution systems: Modeling, simulation and implementation," 2021 The Authors. The Journal of Engineering published by John Wiley & Sons Ltd on behalf of The Institution of Engineering and Technology, <https://doi.org/10.1049/tje2.12005>.