



# International Journal for Innovative Engineering and Management Research

A Peer Reviewed Open Access International Journal

www.ijiemr.org

## COPY RIGHT

**2017 IJIEMR.** Personal use of this material is permitted. Permission from IJIEMR must be obtained for all other uses, in any current or future media, including reprinting/republishing this material for advertising or promotional purposes, creating new collective works, for resale or redistribution to servers or lists, or reuse of any copyrighted component of this work in other works. No Reprint should be done to this paper, all copy right is authenticated to Paper Authors

IJIEMR Transactions, online available on 17<sup>th</sup> October 2017. Link :

<http://www.ijiemr.org/downloads.php?vol=Volume-6&issue=ISSUE-11>

Title: An Enhanced Grid Interfaced System By Using Dual Voltage Source Inverter.

Volume 06, Issue 11, Page No: 26 – 32.

Paper Authors

\* **BADHAVATH PRASAD, BANOTH VIJAYA.**

\* Ellenki College of Engineering and Technology.



USE THIS BARCODE TO ACCESS YOUR ONLINE PAPER

To Secure Your Paper As Per **UGC Guidelines** We Are Providing A Electronic Bar Code

## AN ENHANCED GRID INTERFACED SYSTEM BY USING DUAL VOLTAGE SOURCE INVERTER

**\*BADHAVATH PRASAD, \*\*BANOTH VIJAYA**

Ellenki College of Engineering and Technology, Patalguda Village, Patancheru Mandal, Medhak District.

Ellenki College of Engineering and Technology, Patalguda Village, Patancheru Mandal, Medhak District.

[Bvijaya203@gmail.com](mailto:Bvijaya203@gmail.com)

[Badhavath.prasad5@gmail.com](mailto:Badhavath.prasad5@gmail.com)

**ABSTRACT:** This paper presents the study of Dual Voltage Source Inverter schemes based on control algorithm principles as per Instantaneous Symmetrical Component Theory for operating in grid applications. The proposed scheme comprises of Main Voltage Source Inverter (MVSI), Auxiliary Voltage Source Inverter (AVSI) by enabling the microgrid to exchange the power generated by distributed energy resources (DERs) and also to compensate the local nonlinear load. The control algorithms have been slightly modified with respect to taking the consideration of power loss calculations, after the study of both SRF & ISCT methods, to operate DVSI in grid sharing and grid injecting modes. The proposed scheme has increased reliability, lower bandwidth requirement of the main inverter, lower cost due to reduction in filter size, and better utilization of microgrid power while using reduced dc-link voltage rating for the main inverter. We explored the features that make the DVSI a better option for supplying sensitive loads. The proposed results are verified with MATLAB / Simulink based simulations.

**KEYWORDS** - AVSI-Auxiliary Voltage Source Inverter, DVSI-dual voltage source inverter, Instantaneous symmetrical component theory (ISCT), MVSI-Main Voltage Source Inverter.

### I. INTRODUCTION

The renewable energy sources are integrated to the network with Distributed Generation (DG). These DG units with co-ordinate control of local generation and storage facilities form a microgrid [1]. In microgrid, power from various renewable sources are interfaced with grid and loads using power electronic converters [1], [2]. A microgrid inverter is used to exchange the power from microgrid to the grid and connected load. This microgrid inverter can be operated in grid sharing mode for supplying a part of local load, and in grid injecting mode for injecting power to main grid. In general the

unbalanced load causes low voltage on one leg, power delivery problems and resonance breakdown problems inside the motor or system. If there is a considerable amount of feeder impedance in the distribution systems, the propagation of the harmonic currents distorts the voltage at the point of common coupling (PCC). Industry automation has reached to a very high level of comfortable, plants like auto mobiles manufacturing units, chemical factories, and semiconductor industries required accurate power. The microgrid inverter is used for active power injection as well as for load compensation; the

inverter capacity that can be used for fulfilling the second task is decided by the available

instantaneous microgrid real power. Consider an example of a grid-connected PV inverter, the available capacity of the inverter to supply the reactive power becomes less during the maximum solar insolation periods. At the same instant, the reactive power to regulate the PCC voltage is very much needed during this period [2]. It indicates that providing multifunctionalities in a single inverter degrades either the real power injection or the load compensation capabilities. This paper describes a dual voltage source inverter (DVSI) scheme, in which the power generated by the microgrid is injected as real power by the main voltage source inverter (MVSI) and the reactive, harmonic, and unbalanced load compensation is performed by auxiliary voltage source inverter (AVSI). This has an advantage that the rated capacity of MVSI can always be used to inject real power to the grid [4], if sufficient renewable power is available at the dc link. In the DVSI scheme, as total load power is supplied by two inverters, power losses across the semiconductor switches of each inverter are reduced. This increases its reliability as compared to a single inverter with multifunctional capabilities. Also, smaller size modular inverters can operate at high switching frequencies with a reduced size of interfacing inductor, the filter cost gets reduced. The inverters in the proposed scheme use two separate dc links. Since the auxiliary inverter is supplying zero sequence of load current, a three-phase three-leg inverter topology with a single dc storage capacitor can be used for the main inverter [5]. This in turn reduces the dc-

link voltage requirement of the main inverter. Thus, the use of two separate inverters in the proposed DVSI scheme provides increased reliability, better utilization of microgrid power, reduced dc grid voltage rating, less bandwidth requirement of the main inverter, and reduced filter size. Control algorithms are developed by instantaneous symmetrical component theory (ISCT) to operate DVSI in grid-connected mode, while considering nonstiff grid voltage [6]. The extraction of fundamental positive sequence of PCC voltage is done by  $dq0$  transformation [9]. The control strategy is tested with two parallel inverters connected to a three-phase four-wire distribution system. Effectiveness of the proposed control algorithm is validated through detailed simulation results.

## II. The DVSI

### 2.1 System Topology

The proposed DVSI system is consisting of a neutral point clamped (NPC) inverter to realize AVSI and a three-leg of four wire system for DVSI. These are connected to grid at the PCC and supplying a nonlinear and unbalanced load. The function of the AVSI is to compensate the reactive, harmonics, and unbalance components linearly in load currents [7]. Here, load currents in three phases are represented by  $i_{la}$ ,  $i_{lb}$ , and  $i_{lc}$  respectively. Also,  $i_s(abc)$ ,  $i_m(abc)$ ,  $i_a(abc)$  and  $i_{sn}$  shows grid currents, MVSI currents, AVSI currents and source neutral current in three phases, respectively. The dc link of the AVSI utilizes a split capacitor topology, with two capacitors  $V_{dc1}$  and  $V_{dc2}$ . The MVSI delivers the available power at DER to grid. The DER ( $V_{dcm}$ ) can be a dc source or an ac source with rectifier coupled to dc link. The power generated from these sources use a

power conditioning stage before it is connected to the input of MVSI. In this study, DER is being represented as a dc source. Due to the controller of SRFT, it mainly works on the pulse is given to their DVSI switch then the system has to be equalized.

## 2.2 System configuration and Design

**2.2.1 AVSI:** The important parameters of AVSI like dc-link voltage ( $V_{dc}$ ), dc storage capacitors ( $C1$  and  $C2$ ), interfacing inductance ( $L_{fx}$ ), and hysteresis band ( $\pm h_x$ ) are selected based on the design method of split capacitor DSTATCOM topology [2], [3]. The dc-link voltage across each capacitor is taken as 1.6 times the peak of phase voltage. The total dc-link voltage reference ( $V_{dcref}$ ) is found to be 1040 V. Values of dc capacitors of AVSI are chosen based on the change in dc-link voltage during transients. Let total load rating is  $S$  kVA. In the worst case, the load power may vary from minimum to maximum, i.e., from 0 to  $S$  kVA. AVSI needs to exchange real power during transient to maintain the load power demand. This transfer of real power during the transient will result in deviation of capacitor voltage from its reference value. Assume that the voltage controller takes  $n$  cycles, i.e.,  $nT$  seconds to act, where  $T$  is the system time period. Hence, maximum energy exchange by AVSI during transient will be  $nST$ . This energy will be equal to change in the capacitor stored energy. Therefore

$$\left(\frac{1}{2}\right) C_{dc} [(V_{dc})^2 - (V_{dc1})^2] = nST \quad (1)$$

Where  $V_{dcr}$  and  $V_{dc1}$  are the reference dc voltage and maximum permissible dc voltage across  $C1$  during transient, respectively. Here,

$S = 5$  kVA,  $V_{dcr} = 520$  V,  $V_{dc1} = 0.8 * V_{dcr}$  or  $1.2 * V_{dcr}$ ,  $n = 1$ , and  $T = 0.02$  s. Substituting these values in (1), the dc link capacitance ( $C1$ ) is calculated to be 2000  $\mu$ F. Same value of capacitance is

selected for  $C2$ . The interfacing inductance is given by

$$L_{fx} = \left(\frac{1.6 V_m}{4n_x f_{max}}\right). \quad (2)$$

Assuming a maximum switching frequency ( $f_{max}$ ) of 10 kHz and hysteresis band ( $h_x$ ) as 5% of load current (0.5 A), the value of  $L_{fx}$  is calculated to be 26 mH. **2.2.2 MVSI:** The MVSI uses a three-leg inverter topology. Its dc-link voltage is obtained as  $1.15 * V_{ml}$ , where  $V_{ml}$  is the peak value of line voltage. This is calculated to be 648 V. Also, MVSI supplies a balanced sinusoidal current at unity power factor [9]. So, zero sequence switching harmonics will be absent in the output current of MVSI. This reduces the filter requirement for MVSI as compared to AVSI [10]. In this analysis, a filter inductance ( $L_{fm}$ ) of 5 mH is used.

## III. CONTROL STRATEGIES FOR DVSI SCHEME

The control algorithm for reference current generation using ISCT requires balanced sinusoidal PCC voltages. Because of the presence of feeder impedance, PCC voltages are distorted. Therefore, the fundamental positive sequence components of the PCC voltages are extracted for the reference current generation [2]. To improve the power quality we have modified the circuit as shown in the following Fig.1. The control strategies and techniques shown in [4] to [10] have been studied before modifications. The Fundamental

Voltage Extraction as per [1]&[2] and Instantaneous Symmetrical Component theory are as per [2] and major change in power calculations are shown in the Fig.1. Mathematical analysis is referred as per the concept mentioned in [1] & [2]. Major difference is change in the computation of Power loss alone as shown in the Fig. 1.

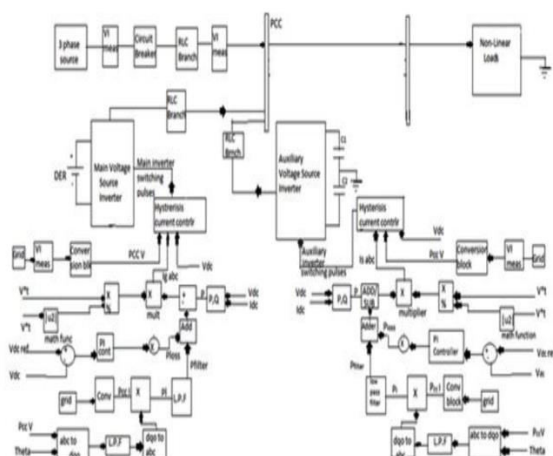

Fig.1 Control strategy of DVSI scheme

## IV. SIMULATION STUDIES

The simulation model of DVSI scheme shown in Fig.2 is developed in MATLAB / Simulink 2011a to evaluate the performance. The model shows that the main grid is connected with the nonlinear loads. Due to these nonlinear loads the grid voltages and currents are also nonlinear in nature. The load demand is also considered greater than supply. So in order to inject the required load power and to suppress the nonlinearities, DVSI is being connected to the grid at the point of common coupling. This DVSI is consisting of two inverters called MVS and AVS. The arrangement of parameters of both MVS and AVS are entirely different and the purpose of installing the both are also different. The MVS is connected with the Distributed Energy

Resources (DER). The output power of DER is given as an input to the MVS and the output of the MVS is connected to the grid. On the other hand, the AVS is connected with two capacitors arrangement as shown in Fig.2.

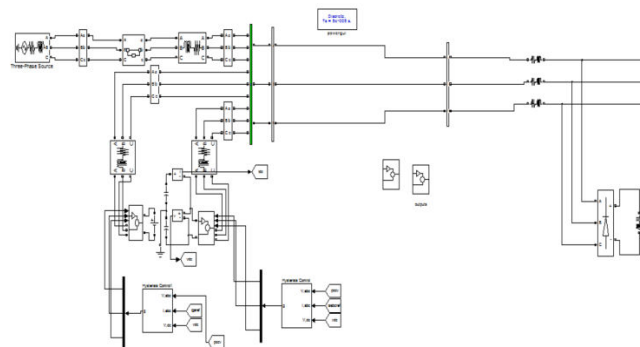

Fig.2 Simulation model of the DVSI scheme.

This special arrangement is made for the purpose of injecting the reactive power into the grid, which is required by the nonlinear load. Hence the DVSI system is able to supply the active power required by the load by MVS and to supply reactive power required by the load by the AVS. In order to cooperate both MVS and AVS, it is required to collect the reference currents, in order to get the pulses as an input to the voltage source inverters. The simulation parameters of the system are given in Table I.

Table I System parameters for simulation.

| Parameters                             | Values  |
|--|---|
| Source voltage                         | 50 V L-N (rms), 50 Hz   |
| Feeder impedance                       | $R_f = 0.5 \Omega, L_f = 1mH$   |
| Reference DC-link voltage of AVS       | $V_{dcref} = 220V$  |
| DC-link capacitance of AVS             | $C_1 = C_2 = 4700\mu F$   |
| DC-link voltage of MVS                 | $V_{dcm} = 150V$  |
| PI gains of DC-link voltage controller | $K_{Pv} = 80, K_{Iv} = 0.08$  |
| Hysteresis band (h)                    | $\pm 0.15A$   |
| Interfacing inductor (AVS)             | $R_{fx} = 0.5\Omega, L_{fx} = 10mH$   |
| Interfacing inductor (MVS)             | $R_{fm} = 0.5\Omega, L_{fm} = 5mH$  |
| Unbalanced linear load                 | $Z_{a1} = 24 + j16\Omega$<br>$Z_{b1} = 36 + j16\Omega$<br>$Z_{c1} = 64 + j21\Omega$ |
| Nonlinear load                         | 3 $\phi$ diode bridge rectifier with a dc current of 2.4 A                          |

The simulation study demonstrates the grid sharing and grid injecting modes of operation of DVSI Scheme. The Active Power sharing by the grid and DVSI are shown in Fig.3. The load currents, Grid Currents, MVSI Currents, AVSI Currents, distorted PCC voltages due to the feeder impedance, the load reactive power ( $Q_l$ ), reactive power supplied by AVSI ( $Q_x$ ), and reactive power supplied by MVSI ( $Q_{\mu g}$ ), are shown Figure 3-7 respectively. It shows that total load reactive power is supplied by AVSI, as expected.

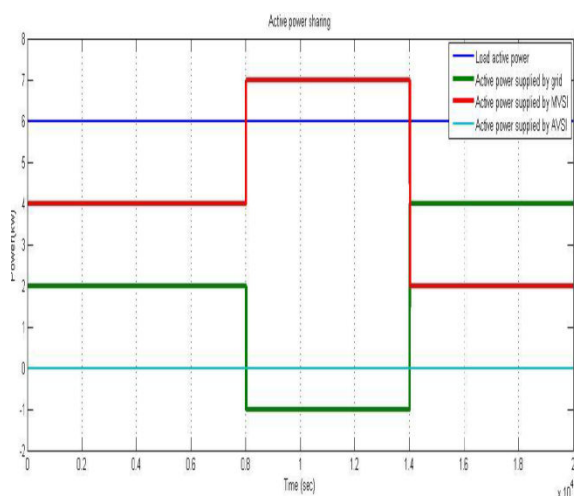
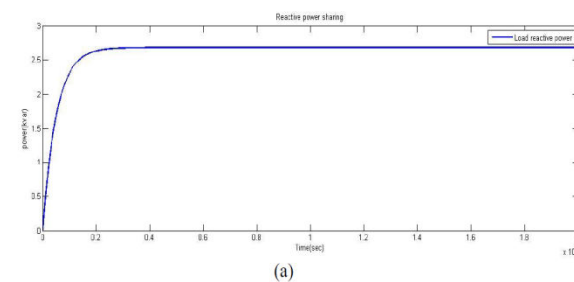
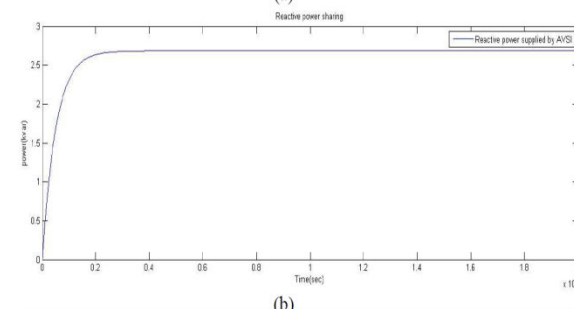

Fig.3 Active power sharing



(a)



(b)

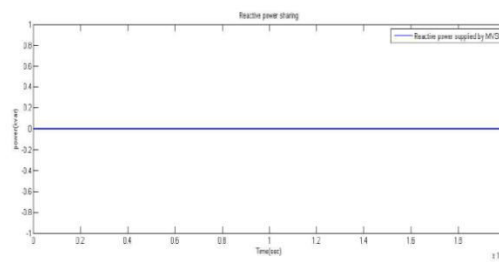

(c)

Fig.4 Reactive power sharing. (a) Reactive power required by load (b) reactive power supplied by AVSI (c) reactive power supplied by MVSI

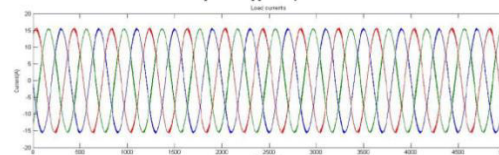

(a)

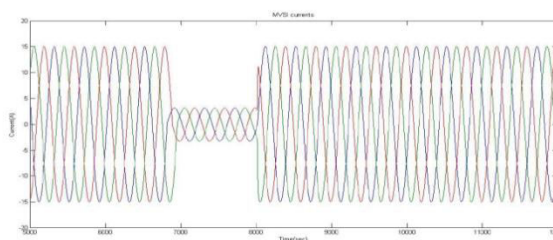

(b)

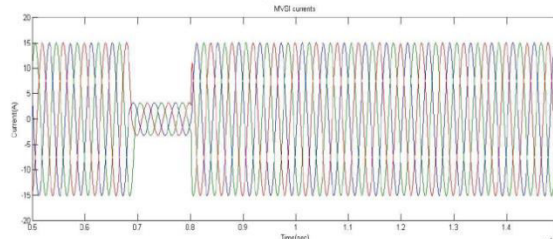

(c)

Fig.5 Simulated performance of DVSI scheme. (a) Load currents (b) Grid currents (c) MVSI currents

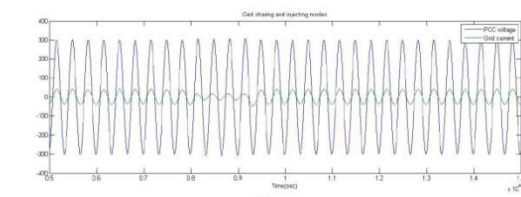

(a)

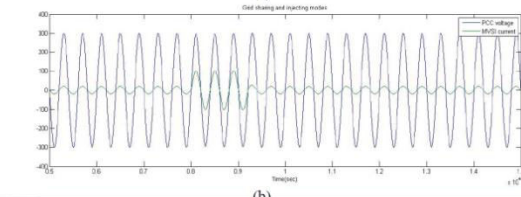

(b)

Fig.6 Grid sharing and grid injecting modes of operation (b) PCC voltage and MVSI current

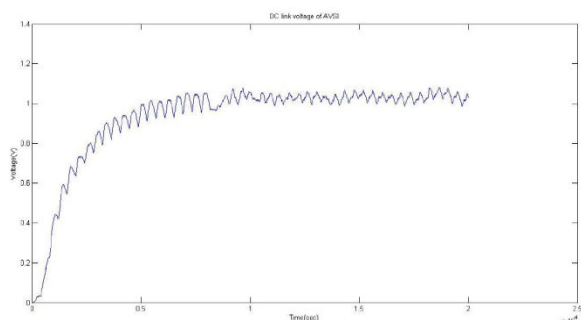

Fig.7 DC-link voltage of AVSI.

## V. CONCLUSION

A DVSI scheme is proposed for microgrid systems with enhanced power quality. Control algorithms are developed to generate reference currents for DVSI using ISCT. The proposed scheme has the capability to exchange power from distributed generators (DGs) and also to compensate the local unbalanced and nonlinear load. The performance of the proposed scheme has been validated through simulation studies. As compared to a single inverter with multifunctional capabilities, a DVSI has many advantages such as, increased reliability, lower cost due to the reduction in filter size, and more utilization of inverter capacity to inject real power from DGs to microgrid. Moreover, the use of three-phase, three wire topology for the main inverter reduces the dc-link voltage requirement. Thus, a DVSI scheme is a suitable interfacing option for microgrid supplying sensitive loads.

## REFERENCES

[1]. A.Naveen Kumar, A.Dheepanchakkravarthy, Prof.Jebasalma, "A Modern Approach of Three Phase Four Wire DVSI for Pq Improvement using SRF Theory", IJRET, ISSN:2278-0181, Vol.5, Issue 03, March-2016.

[2]. M.V.Manoj Kumar, Mahesh.K.Mishra and Chandan Kumar, "A Grid-connected Dual Voltage Source Inverter With Power Quality Improvement Features," IEEE Transactions on Sustainable Energy, Vol. 6, No.2, pp. 482-490, April 2015.

[3]. Nikhila Emerson, S.Srinivasan, "Enhancement of Power Quality in Distributed Generation Resources Using ANT COLONY Optimization", IJAICT Vol.1, Issue 11, ISSN 2348-9928, March 2015.

[4]. KavaliHemadri, V.VeeraNagi Reddy, "Power Quality Enhancement in Distribution System Using ANN based DSTATCOM", IJSTER, Vol.4, Issue 5, May 2015.

[5]. J.Seeralan, V.Karthikeyan, "A Grid Power Quality Enhancement by Dual Voltage Source Inverter", International Research Journal in Advanced Engineering and Technology(IRJAET), Vol.1, Issue 4, pp.365-371, November 2015.

[6]. N. R. Tummuru, M. K. Mishra, and S. Srinivas, "Multifunctional VSC controlled microgrid using instantaneous symmetrical components theory," IEEE Trans. Sustain. Energy, vol. 5, no. 1, pp. 313–322, January 2014.

[7]. J.Guerro, P.C.Loh, T.-L Lee, and M.Chandorkar, "Advanced Control Architecture for intelligent Microgrids- Part II: Power quality, energy storage, and ac/dc Microgrids", IEEE Trans. Ind.Electron., Vol.60, No.4, pp.1263 -1270, December 2013.

[8]. A.Kahrobaeian and Y.R.Mohamed, "Interactive distributed generation interface for flexible microgrid operation in smart distribution systems", IEEE Trans. Sustain. Energy, Vol. 3, No.2, pp.295-305, April 2012.



[9]. Y.Zhang, N.Gatsis, and G.Giannakis, “Robust energy management for Microgrids with high-penetration renewables”, *IEEE Trans. Sustain. Energy*, Vol.4, No.4, pp.944-953, October 2013.

[10]. M.Schonardie, R.Coelho, R.Schweitzer, and D.Martins, “Control of the active and reactive power using dq0 transformation in a three-phase grid-connected PV system”, in *Proc.IEEEInt.Symp.Ind.Electron.*, pp.264-269, May 2012.